

# User Guide MXm and MXq

Release 1.00

---





## INDEX

1 – MXm and MXq in a few words	4
2 – What is in the kit?	5
3 – Powering	5
4 – At power on	6
5 – What you can do via keyboard	7
5.1 – MXm settings available via keyboard	7
5.1.1 – Type of Race	8
5.1.2 – Backlight	8
5.1.3 – WiFi	9
5.1.4 – Tracks Management	10
5.1.5 – Counters	11
5.1.6 – Date and Time	12
5.1.7 – Language	12
5.1.8 – System Info	13
5.2 – MXq settings available via keyboard	14
5.2.1 – Backlight	15
5.2.2 – WiFi	15
5.2.3 – Track Management	16
5.2.4 – Counters	17
5.2.5 – Date and time	18
5.2.6 – Language	18
5.2.7 – System Info	18
5.2.8 – Demo mode	19
6 – MXm/MXq and the PC	19
6.1 – Connection to the PC	19
6.1.1 – Wi-Fi configuration	21
6.1.2 – Configuring the logger as an access point (AP)	23
6.1.3 – Adding the logger to an existing network	26
6.1.4 – Wi-Fi network settings	28
6.1.5 – The Internet connectivity	29
6.1.6 – Connection issues	29
6.1.7 – Working on Mac™ with virtualized Windows™	30
6.1.8 – Connected device visualization issues	32
6.2 – Configuration	33
6.2.1 – Channels configuration	34
6.2.2 – ECU Connection and configuration	37
6.2.3 – AiM CAN Expansions configurations	38
6.2.4 – Math channels	40
6.2.5 – Status variables setting	41
6.2.6 – Parameters settings	46
6.2.7 – Shift Lights and Alarms	47
6.2.8 – Commands	53
6.2.9 – Power Outputs setting (MXm only – expert users only)	54
6.2.10 – Display settings	58
6.2.11 – SmartyCam stream setting	60
6.2.12 – CAN Output	62
6.3 – Managing a track with RaceStudio 3	63
6.4 – ECU Driver builder (expert users only)	67
6.5 – The device window	68
7 – On the track	72
7.1 – Track page	72
7.2 – Other pages	72
8 – Data recall	73
9 – Data download	75
10 – Data Analysis	76
11 – New firmware upgrade	78



12 – RPM	79
12.1 – RPM from ECU	79
12.2 – RPM via a 5-50V square wave or coil (150-400V)	79
13 – Connection with SmartyCam	82
14 – Technical specifications and drawings	83



## 1 – MXm and MXq in a few words

---

### What are MXm and MXq?

MXm and MXq are the new compact AiM mini loggers that combine small dimensions, usability and logging capability.

### Why buying an MXm or an MXq?

Because they feature:

- ECU connection
- 2 speed inputs (**MXm only**)
- 4 analog inputs for **MXm** and 1 analog input for **MXq**
- 2 digital high side output (**MXm only**)
- up to 8 configurable display pages
- integrated GPS + Glonass receiver
- a huge tracks database to automatically select the track you are racing on
- a powerful and comfortable Wi-Fi connection
- 5 RGB LEDs that clearly show if you are improving or not
- a 4GB internal memory capable of recording a lot of tests

### What about ECU connection?

MXm and MXq manage ECU connections as well as all the communication lines: CAN, K-Line, RS232. Its huge database includes more than 1500 protocols you can load in your logger.

### If the vehicle does not have an ECU?

In case your vehicle does not have an ECU, you can connect MXm or MXq to an RPM square wave to synchronize RPM to the position on the track thanks to the RPM cable of the logger harness.

### Are MXm and MXq expandable loggers?

Yes. they can be connected to numerous AiM CAN expansions to maximize your engine performances as well as to AiM SmartyCam to see your track performances on your PC with all the values you need in overlay.



## 2 – What is in the kit?

---

**MXm** kit includes:

- MXm
- 37 pins connector harness
- 4 pins connector kit
- USB cable

**Optional and spare parts** part numbers are:

- 37 pins connector + USB harness (V02573310)
- 4 pins DTP 06-4S EE01 connector kit with pins (X87KCDTP064S)
- USB cable (V02573200)

**MXq** available kits are:

**MXq+ CAN/RS232**; it includes

**XMxQCRS200**

- MXq
- 200 cm CAN/RS232 + External power cable

**MXq + CAN/K-Line/OBDII**; it includes

**XMxQOBD200**

- MXq
- 200 cm CAN/K-Line/OBDII + External power cable

**MXq + RPM**; it includes

**XMxQRPM200**

- MXq
- 200 cm RPM + External power cable

**Optional and spare parts** part numbers are:

- 200 cm CAN/RS232+External power cable (V02589050)
- 200 cm CAN/L-Line/OBDII + External power cable (V02589040)
- 200 cm RPM + External power cable

## 3 – Powering

---

Both loggers are to be connected to the vehicle master switch. This way they switch ON/OFF with the vehicle engine.

**MXm** is powered through the 37 pins connection harness wires labelled "9-15 VDC" and "GND".

**MXq** is powered using through the 5 pins Binder 712 female connector wires labelled +"Vbext" and "GND".

## 4 – At power on

When switched on both loggers show satellite page.

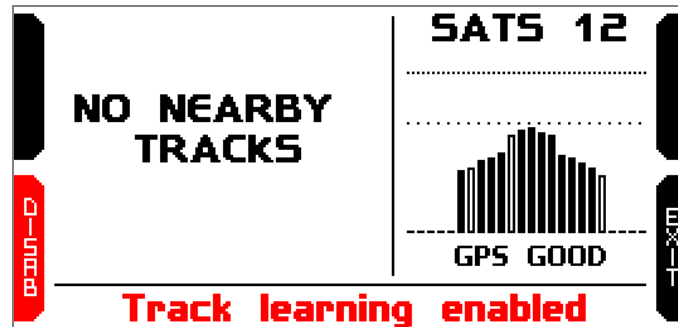

Here you can see the number of connected satellite (SATS 12 in the image above) as well as the quality of the signal.

If you are on a track not included in the logger database the system shows the message “NO NEARBY TRACKS and automatically enables track learning. You can disable it pressing the related button. Pressing the related button it switches from ENABLE to DISABLE each time. The system asks for confirmation.

## 5 – What you can do via keyboard

Both loggers are mainly configurable using RaceStudio 3 software but some functions are settable via keyboard pressing “MENU” button as explained here below.

### 5.1 – MXm settings available via keyboard

MENU page is shown below.

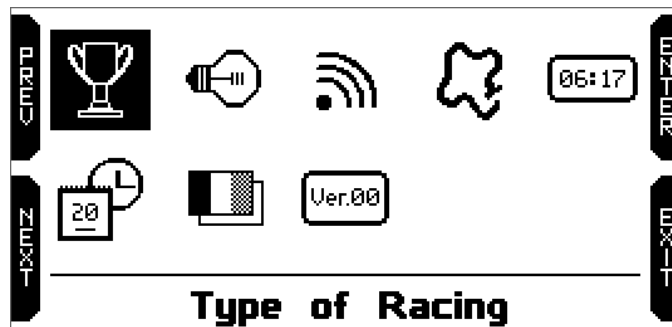

The icons are to manage:



Type of Race



Tracks

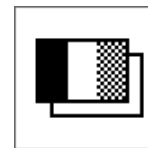

Language

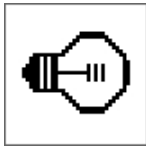

Backlight



Counters



System Info



Wi-Fi settings



Date and Time



## 5.1.1 – Type of Race

MXm race mode is predictive; it shows the gap time between the current predictive lap time and a lap time used as reference one. Available reference laps are:

- Best lap of the test
- Best Lap of today
- Previous Lap
- User reference lap

Use:

- "CHANGE" to change reference lap
- "EXIT" to save and exit

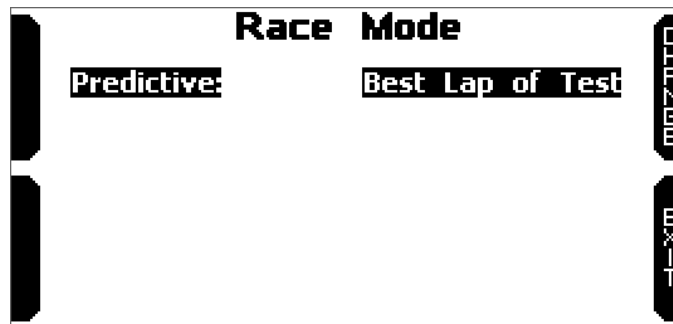

## 5.1.2 – Backlight

You can set MXm backlight as "AUTO" (Default setting), "ON" or "OFF".

Thanks to the light sensor, placed left on the front of MXm, "AUTO" setting switches the backlight on/off according to the ambient light conditions.

MXm backlight can be: white, purple, red, green, yellow, blue, magenta and cyan.





### 5.1.3 – WiFi

Here you can manage Wi-Fi status as well as reset its configuration.

**Wi-Fi modes** are:

- ON
- AUTO: switches Wi-Fi on when the vehicle is stopped and automatically switches it off when MXm starts recording, according to the setting you performed in “Parameters” page of RaceStudio 3 software (see paragraph 6.2.6 for further information)
- OFF

Available **Channels** are:

- Auto
- 1
- 6
- 11

Available **ID** are:

- 10.0.0.1
- 11.0.0.1
- 12.0.0.1

Use:

- “CHANGE” to modify the setting
- “PREV” and “NEXT” to scroll the options
- “EXIT” to save and exit

“**Wi-Fi reset CFG**” allows you to reset Wi-Fi configuration and is very useful if you do not remember Wi-Fi password.

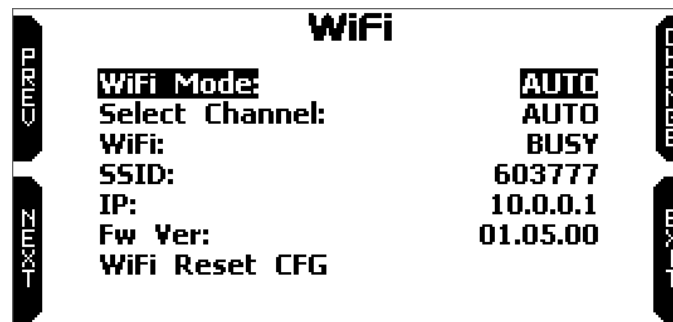



## 5.1.4 – Tracks Management

MXm built in GPS receiver is used for:

- Lap time calculation
- Speed calculation
- Predictive lap time calculation
- Position on the track in analysis

To calculate these data the system needs to know the start/finish line coordinates.

MXm comes with a long list of the world main tracks. The list is constantly updated by our technicians and it updates on your PC when you run RaceStudio 3 software and a connection to the internet is available. Available track selection modes are: automatic and manual.

### Automatic:

the system automatically recognizes the track you are running on, loads start/finish line and calculates lap times. This is the best mode in most cases

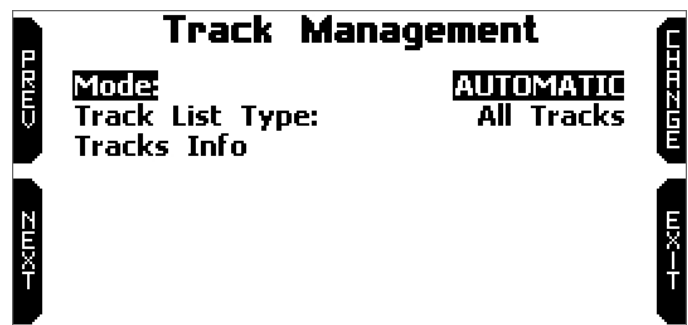

### Manual:

allows you to manually select the track from the internal database.

This mode is to be preferred when multiple configurations of the same track are available nearby. In this case MXm would anyway recognize the track but would need at least one complete track lap.

To be ready from the first lap manual mode would be helpful.



Both track modes provide three track list type:

- nearest: shows only tracks in a 10 km distance with max 50 tracks shown
- all tracks: shows all tracks stored in the system in alphabetical order
- **custom**: shows only the tracks you have previously created with RaceStudio 3 software (see paragraph 6.3); if no custom tracks are stored MXm informs the user.



### 5.1.5 – Counters

This page manages the 4 resettable odometers. The system odometer is not resettable. All odometers are shown on RaceStudio 3 too (see chapter 6 “MXm/MXq and the PC”).

COUNTERS		
System:	00:83	147 km*
Usr 1:	00:23	47 km*
Usr 2:	00:41	87 km*
Usr 3:	00:12	27 km*
Usr 4:	00:30	57 km*
Distance Unit:		km

Each odometer can be activated/deactivated and/or reset. To select the odometer you want to manage press “CHANGE”.

- scroll to Status and press “CHANGE” to switch from “Active” to “Stop” and vice-versa
- scroll to clear and press “CHANGE” to reset an odometer (left image below)
- pressing “EXIT” you come back to odometer page and the odometer you stopped/reset will not show the asterisk and will show “0” km (in the example below both operations have been performed on odometer 1 (right image below)).

Counters		
Usr 1:	00:23	47 km
Status:		Active
Clear		

COUNTERS		
System:	00:83	147 km*
Usr 1:	00:23	0 km
Usr 2:	00:41	87 km*
Usr 3:	00:12	27 km*
Usr 4:	00:30	57 km*
Distance Unit:		km

MXm allows the user to switch from international to Imperial measure units and re-computes the corresponding values as shown here below.

COUNTERS		
System:	00:83	147 km*
Usr 1:	00:23	47 km*
Usr 2:	00:41	87 km*
Usr 3:	00:12	27 km*
Usr 4:	00:30	57 km*
Distance Unit:		km

COUNTERS		
System:	00:83	91 mi*
Usr 1:	00:23	29 mi*
Usr 2:	00:41	25 mi*
Usr 3:	00:12	16 mi*
Usr 4:	00:30	35 mi*
Distance Unit:		mi



### 5.1.6 – Date and Time

As shown here below on the left here you can set different parameters.

- **Time format** available options are: 24h and 12h
- **Date format:** available options are: DD/MM/YY, YY/MM/DD and MM/DD/YY
- **Date Tyme Sync:** available options are: by GPS track, Manual or by PC

To set Date Time Sync in Manual Mode:

- Press “NEXT” to scroll up to “Date Time Sync” option(right image below)
- Press “CHANGE” until “Manual” option is shown and press “NEXT”

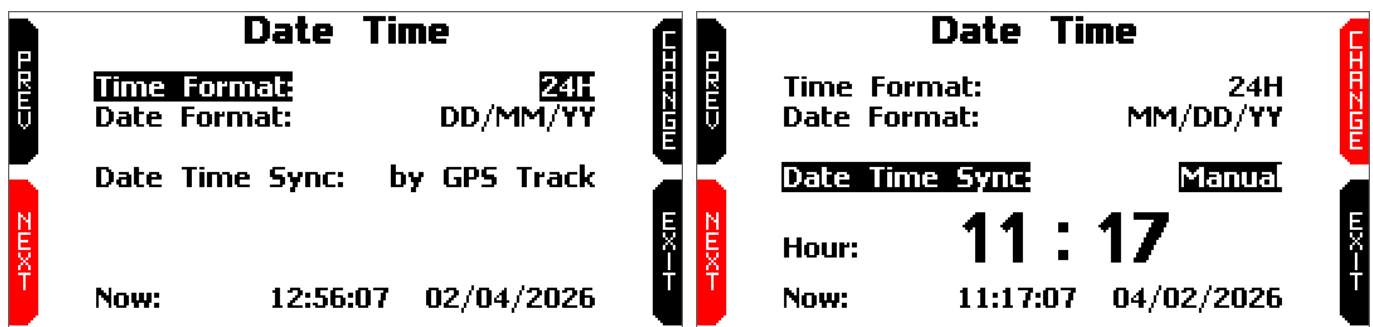

- “Hour” option is selected (left image below): use “DEC” and “INC” buttons to set it
- Press “DESEL; press “NEXT” (right image below)
- Minute option is selected: set it and press “EXIT” to save and exit

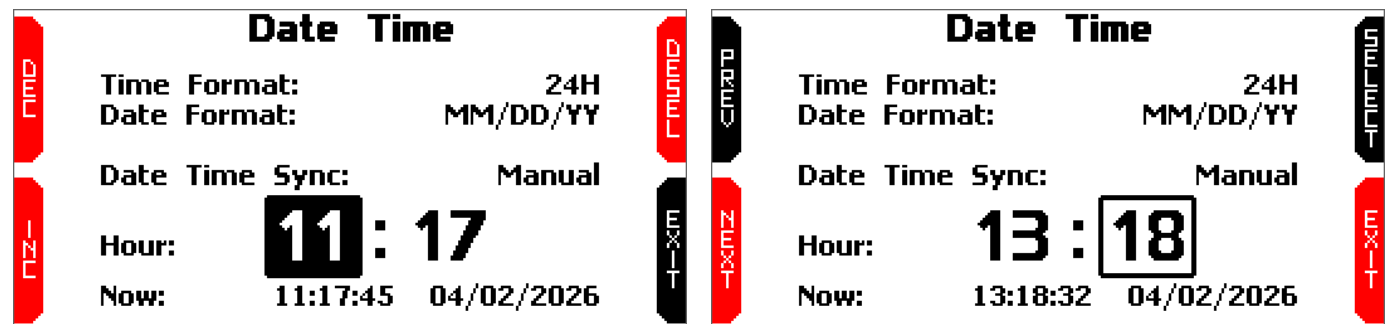

### 5.1.7 – Language



You can set MXm language. Default setting is English. Press “CHANGE” to set the language you prefer. At present available languages are (in this order):

- English
- Italian
- German
- Spanish
- French
- Dutch
- Danish
- Portuguese
- Japanese
- Czech



### 5.1.8 – System Info

This page shows serial number as well as firmware and boot version of your MXm.

```
System Info
Logger:                MXM
Serial N.:             6500100
Fw Version:           02.23.12
Boot Version:         02.22.12
EXIT
```

## 5.2 – MXq settings available via keyboard

MENU page is shown below.

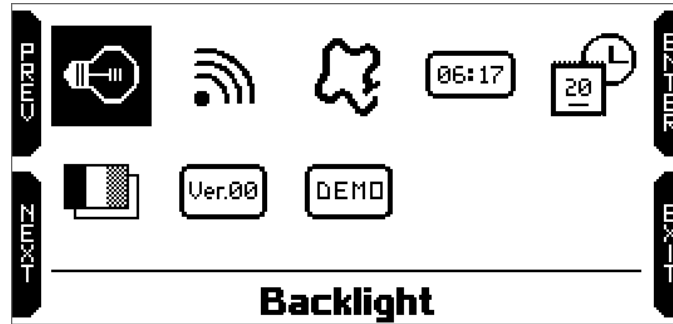

The icons are to manage:

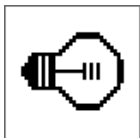

Backlight



Wi-Fi



Tracks



Counters



Date and time

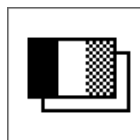

Language



System Info



Demo mode

1



## 5.2.1 – Backlight

You can set MXq backlight as “AUTO” (Default setting), “ON” or “OFF”.

Thanks to the light sensor, placed left on the front of MXq, “AUTO” setting switches the backlight on/off according to the ambient light conditions.

MXq backlight can be: white, purple, red, green, yellow, blue, magenta and cyan.



## 5.2.2 – WiFi



Here you can manage Wi-Fi status as well as reset its configuration. **Wi-Fi modes** are:

- ON
- AUTO: switches Wi-Fi on when the vehicle is stopped and automatically switches it off when MXq starts recording, according to the setting you performed in “Parameters” page of RaceStudio 3 software (see paragraph 6.2.6 for further information)
- OFF

Use:

- “CHANGE” to modify the setting
- “PREV” and “NEXT” to scroll the options
- “EXIT” to save and exit

“**Wi-Fi reset CFG**” allows you to reset Wi-Fi configuration and is very useful if you do not remember Wi-Fi password.

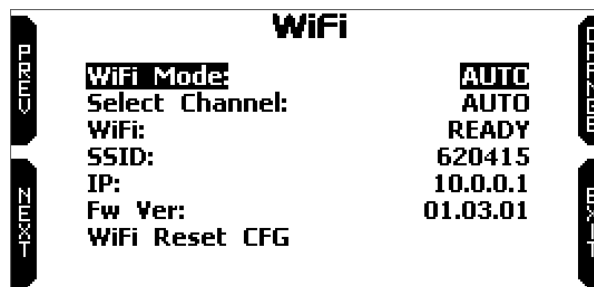



### 5.2.3 – Track Management

MXq built in GPS receiver is used for:

- Lap time calculation
- Speed calculation
- Predictive lap time calculation
- Position on the track in analysis

To calculate these data the system needs to know the start/finish line coordinates.

MXq comes with a long list of the world main tracks. The list is constantly updated by our technicians and it updates on your PC when you run RaceStudio 3 software and a connection to the internet is available. Available track selection modes are: automatic and manual.

**Automatic:**

the system automatically recognizes the track you are running on, loads start/finish line and calculates lap times. This is the best mode in most cases



**Manual:**

allows you to manually select the track from the internal database.

This mode is to be preferred when multiple configurations of the same track are available nearby. In this case MXq would anyway recognize the track but would need at least one complete track lap.

To be ready from the first lap manual mode would be helpful.

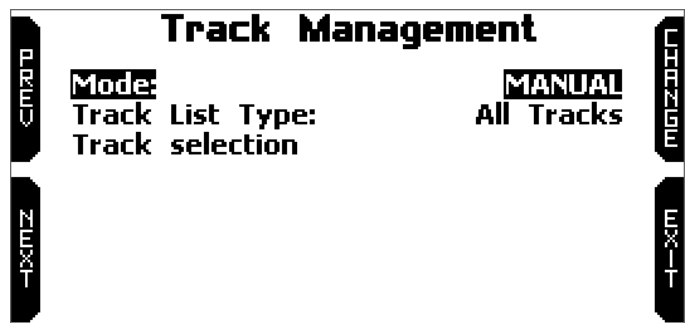

Both track modes provide three track list type:

- nearest: shows only tracks in a 10 km distance with max 50 tracks shown
- all tracks: shows all tracks stored in the system in alphabetical order
- custom: shows only the tracks you have previously created with RaceStudio 3 software (see paragraph 6.3)

### 5.2.4 – Counters

This page manages the 4 resettable odometers of MXq. The system odometer is not resettable. All odometers are shown on RaceStudio 3 too (see chapter 6 “MXm/MXq and the PC”). Each odometer can be activated/deactivated and/or reset. To deactivate an odometer:

- scroll to Status and press “CHANGE” to switch from “Active” to “Stop” and vice-versa

COUNTERS		
System:	00:08	12 mi*
<b>Usr 1:</b>	<b>00:08</b>	<b>12 mi*</b>
Usr 2:	01:08	82 mi*
Usr 3:	00:28	34 mi*
Usr 4:	00:16	28 mi*
Distance Unit:		mi

To reset an odometer:

- scroll to clear and press “CHANGE” (left image below)
- pressing “EXIT” you come back to odometer page and the odometer you stopped/reset will “0” km

Counters		
Usr 1:	00:08	12 mi
Status:		Active
Clear		

COUNTERS		
System:	00:08	12 mi*
<b>Usr 1:</b>	<b>00:00</b>	<b>0 mi*</b>
Usr 2:	01:08	82 mi*
Usr 3:	00:28	34 mi*
Usr 4:	00:16	28 mi*
Distance Unit:		mi

MXq allows the user to switch from international to Imperial measure units and re-computes the corresponding values as shown here below.

COUNTERS		
System:	00:08	12 mi*
Usr 1:	00:08	12 mi*
Usr 2:	01:08	82 mi*
Usr 3:	00:28	34 mi*
Usr44:	00:16	28 mi*
Distance Unit:		mi

COUNTERS		
System:	00:08	19 km*
Usr 1:	00:08	19 km*
Usr 2:	01:08	132 km*
Usr 3:	00:28	55 km*
Usr 4:	00:16	54 km*
Distance Unit:		km



### 5.2.5 – Date and time

Available Date Time synchronization are:

- By GPS track (Default)
- Manual: it needs user to manually fill in date and time
- ByPC: MXq Date/Time is synchronized with the PC when connected to a PC.

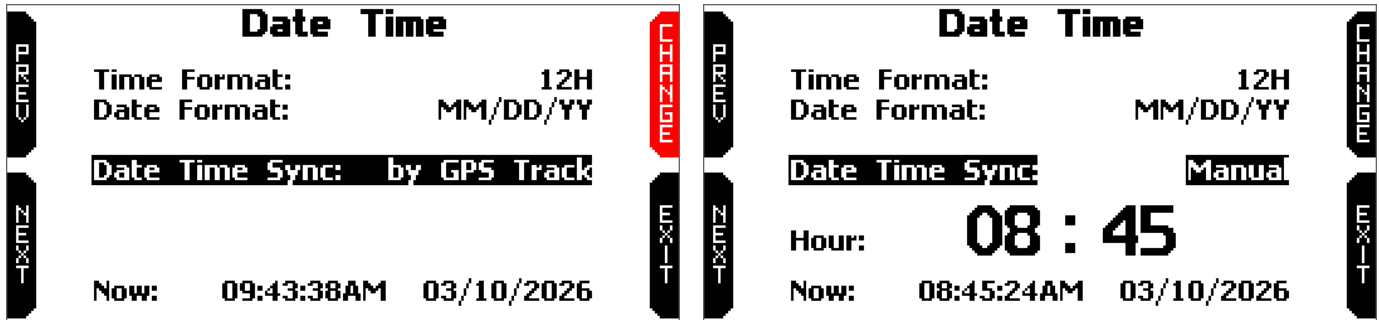

### 5.2.6 – Language

You can set MXq language. Default setting is English. Press "CHANGE" to set the language you prefer. At present available languages are (in this order):

- English
- Italian
- German
- Spanish
- French
- Dutch
- Danish
- Portuguese
- Japanese
- Czech



### 5.2.7 – System Info

This page shows logger type, serial number, firmware and boot version.

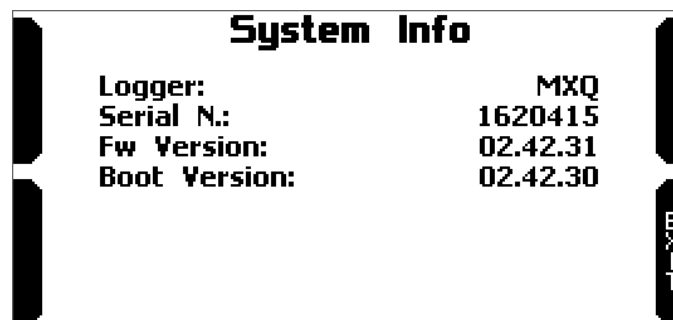



### 5.2.8 – Demo mode

This menu option shows MXq demo mode. Default setting is OFF (left image below). To change this setting:

- Press “CHANGE”
- MXq asks for confirmation: press “YES”
- MXq reboots and starts working in Demo mode.

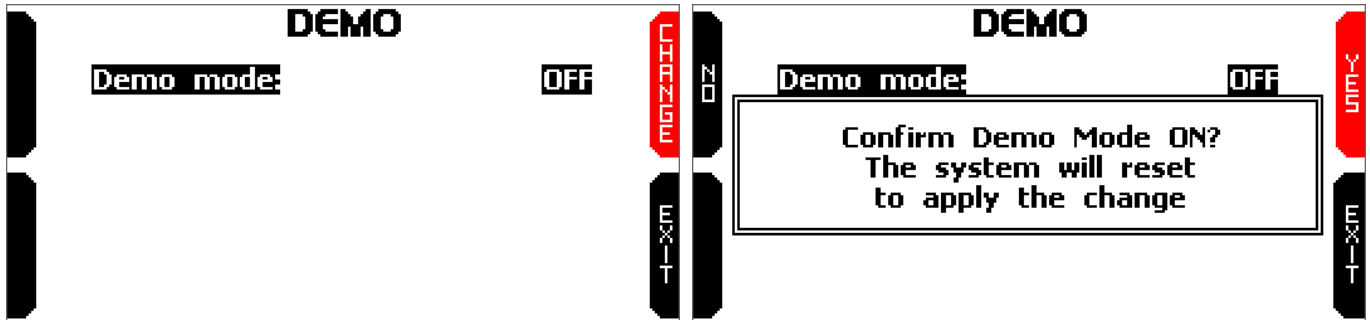

## 6 – MXm/MXq and the PC

Using AiM RaceStudio 3 software you can configure MXm/MXq, manage its tracks database as well as check other device functions.

### 6.1 – Connection to the PC

**MXq** can only be connected to the PC via Wi-Fi **while MXm** can be connected both via Wi-Fi or via USB thanks to the USB cable you find in the kit (plug it in the cable labelled “USB” of MXm 37 pins connector harness and in the PC USB port).

To connect the loggers to the PC via **Wi-Fi**:

- check that the logger Wi-Fi is set on “AUTO” or on “ON”
- read your device name – mid of the home page bottom line – or look for it in system information page
- click RaceStudio 3 Wi-Fi icon and select your device
- press “Connect” and wait just a few moments.

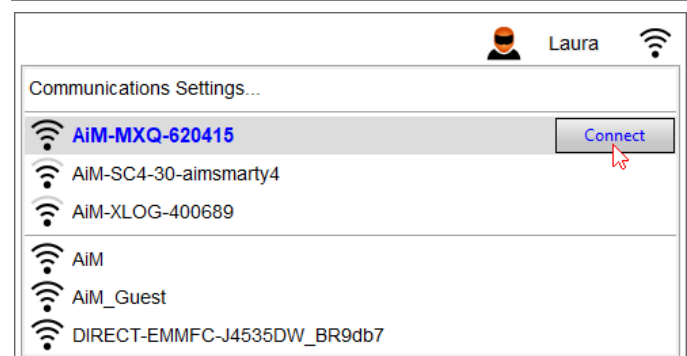
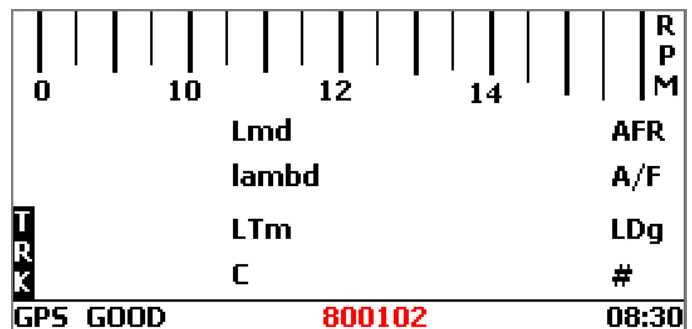



Once the system is connected to the PC the software shows it bottom left of the software home page showing also the way it is connected: USB or Wi-Fi as shown here below. CAMBIARE IMMAGINE

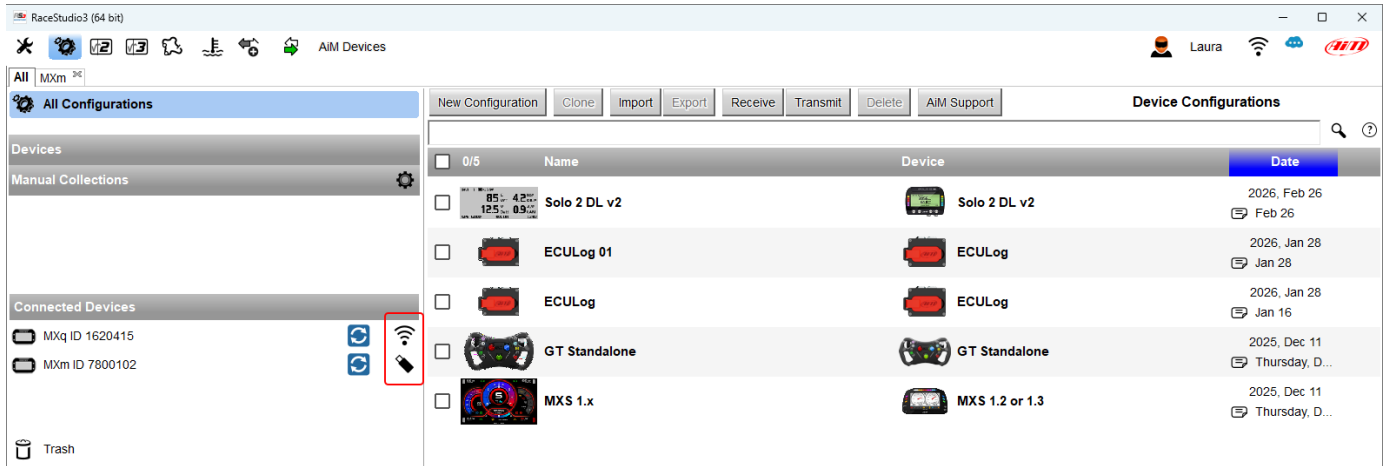

### 6.1.1 – Wi-Fi configuration

---

As far as Wi-Fi connection is concerned two possible Wi-Fi modes are available.

#### 1 – As an access point (AP – default)

This is the ideal configuration if you have one only device and one only computer. In this situation your device creates a Wi-Fi network and works as an Access Point you can connect your PC to. CAMBIARE IMMAGINE.



## 2 – Existing network (to connect to an existing Wi-Fi network – WLAN)

This mode is complex and implies an external access point (AP) but it is also more flexible and powerful because allows you to communicate with more than one device and with more than one computer in the same network. The loggers and the PC must connect to an existing Wi-Fi network made by a device that works as an external access point.

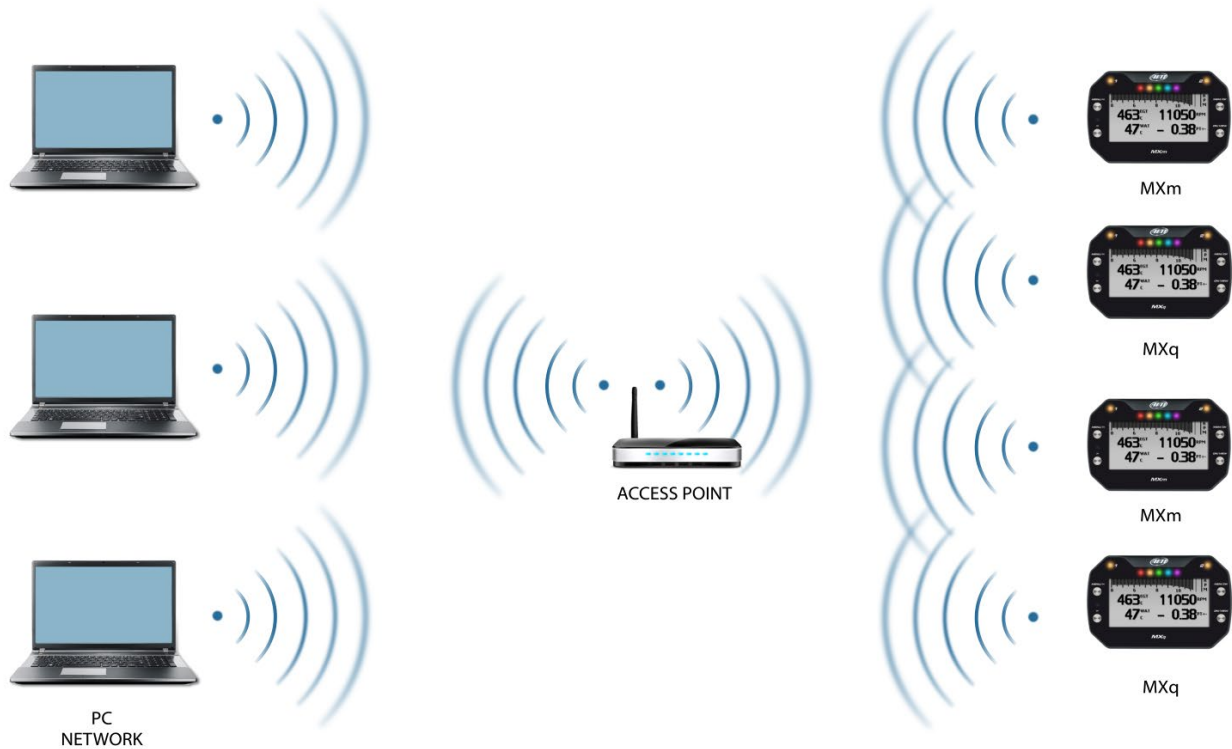

When working in WLAN mode AiM logger has two available security levels:

- network authentication: network password
- device authentication: device password

Both levels allow you to use different strategies. A PC in WLAN, for example, can see several AiM devices but can communicate only with those he knows the password of.

If you forget the password you can reset Wi-Fi configuration from the device menu as explained before.

### 6.1.2 – Configuring the logger as an access point (AP)

This is the default configuration and is the easiest and most direct connection mode, ideal to communicate with one device using one PC. It is free and so completely accessible by anyone. Please set an access password as soon as possible.

To establish a Wi-Fi connection:

- ensure that the Wi-Fi is enabled
- read your device ID bottom of the device home page.

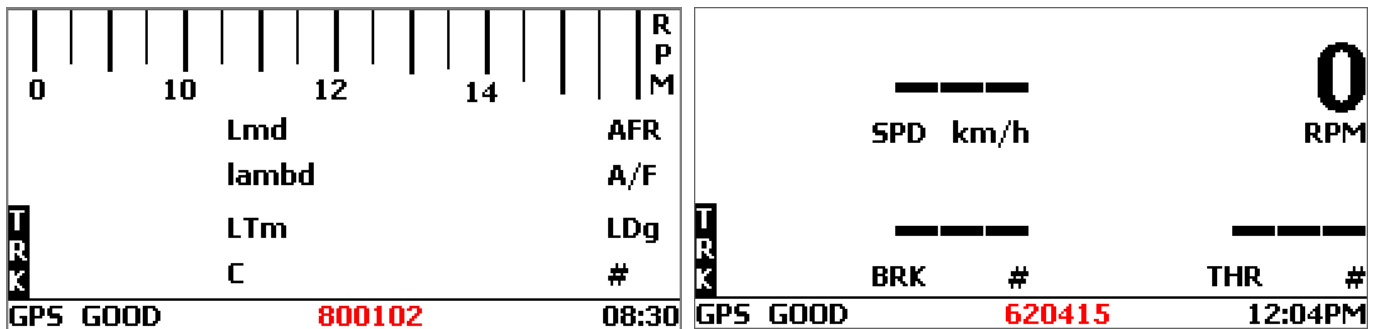

- run RaceStudio 3
- click Wi-Fi icon and select your device
- in a few seconds the connection is established

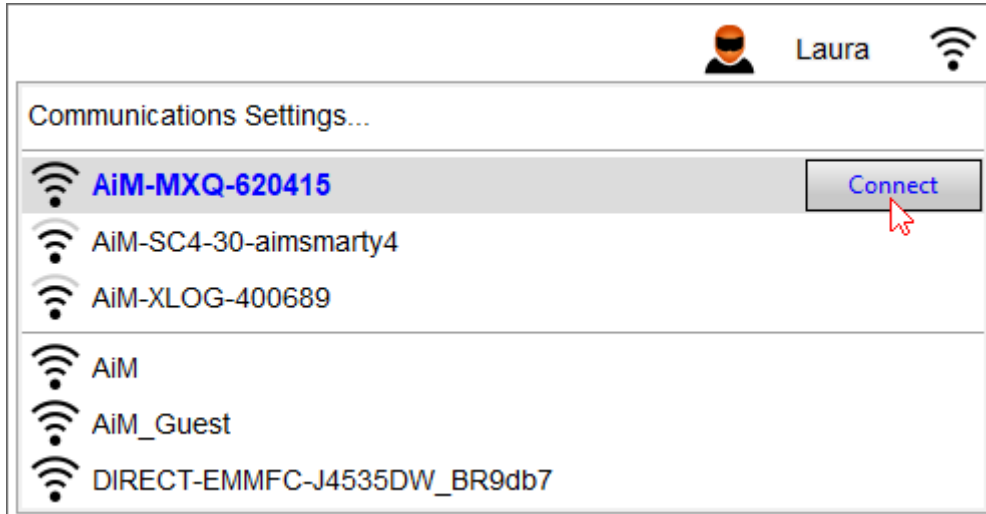

- press "AiM Devices" button top left of the software view
- the device online page is prompted: enter "WiFi and Properties" tab
- WiFi mode and WiFi Network name are shown (in the red boxes here below)

Default setting WiFi network is with free access. To set other parameters create a unique password to protect your device/your network. With a password the communication is safe and encrypted using WPA2-PSK standard.

Characters allowed in the password are all letters, also capital, all digits and these characters: '+- \_()[]{}\$£!?^#@\*\\"=~/,%'" "Space" type can be used if it is not the first one because this could cause incomprehension in some Windows™ versions.

This AP or SSID name is unique for your device.

An example of name is: "AiM-MXq-620415" where:

- "AiM" is the prefix of all AiM devices
- "MXq" is the device identifier
- "620415" is your device serial number assigned by the factory. CAMBIARE IMMAGINE.

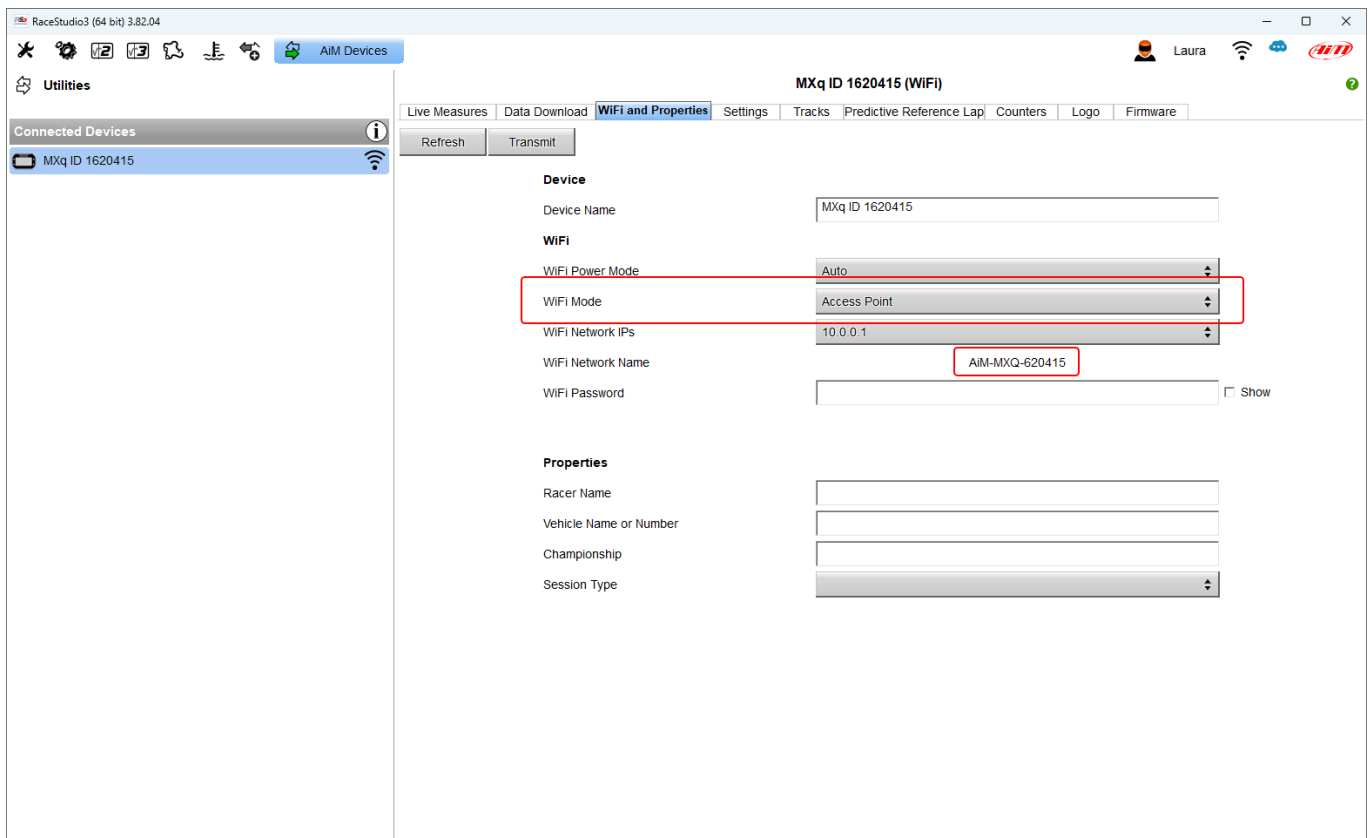



To make your device more recognizable you can add a name to the SSID. The limit is of eight characters. Allowed characters are all letters, capital too, all digits and these characters: '+ - \_ () [] {}!'.

“Space” type can be used provided that it is not the first one because it can cause incomprehension in some Windows™ versions.

If, for example, you add the driver’s name, Tom Wolf, the network name (SSID) becomes:

“AiM-MXQ-620415-TomWolf”

Once all parameters set click “Transmit”. The device reboots and is configured with the new parameters. If it is protected by a password, as recommended, RaceStudio 3 will ask that password to authenticate.

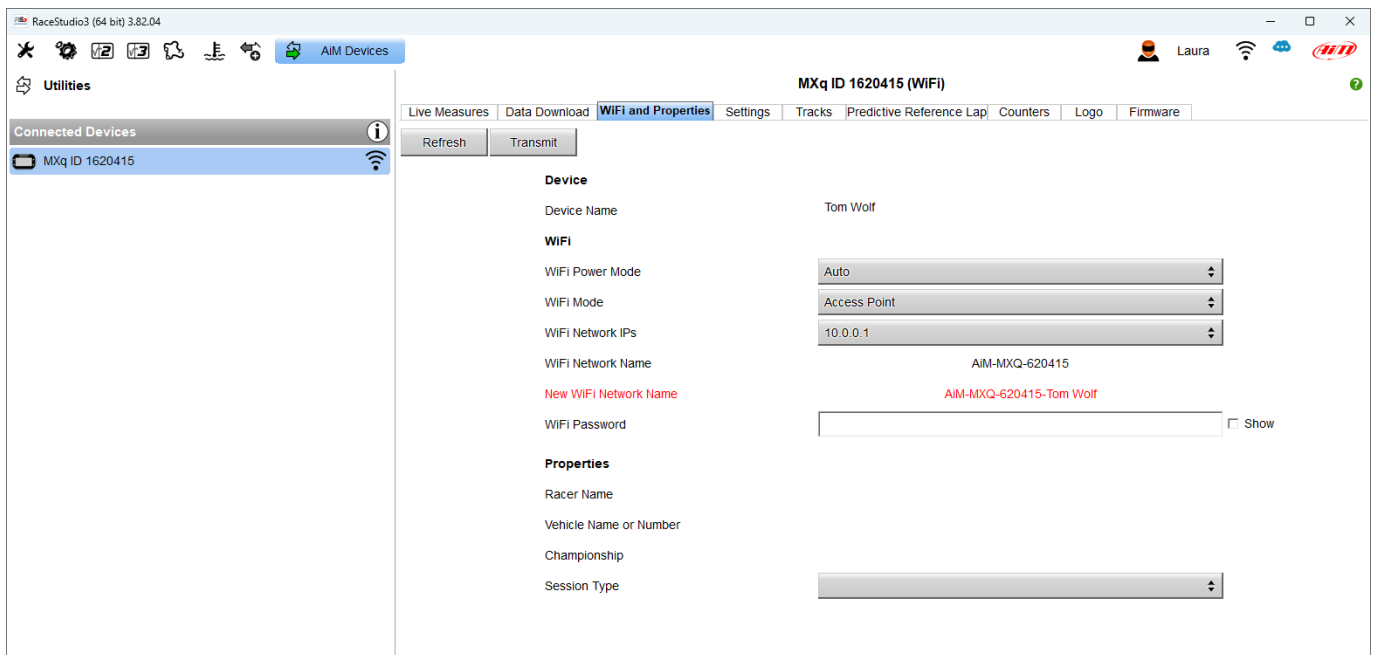

**Please Note:** the same Wi-Fi connection can be created with the operative system tool.

Once the device has been authenticated in the Wi-Fi network you can communicate with it using RaceStudio 3.

## 6.1.3 – Adding the logger to an existing network

This situation is ideal for a team with multiple drivers and staff members and is desired to communicate with one or more AiM devices using the same PC network. Each device can have its password that adds another security and privacy level to the network. RaceStudio 3 will show all devices connected to the same network under “Connected devices” label, bottom left of the software page: click your device.

Enter “Wi-Fi and properties” tab and set it on “Existing Network”; fill in network name, network password and device password if set. Transmit the network settings to your device clicking “Transmit”: your device reboots and joins that network.

**Please note:** the only admitted password are those following WPA2-PSK standard.

To complete this procedure use RaceStudio 3 software as here explained.

Here below you see a device “MXq ID 1620415” that switched from AP to WLAN mode (Existing Network).

Network name is “AiM” and does not work with free access because is protected by a password.

To obtain connectivity on the device the PC has to be authenticated to the same network as shown here below.

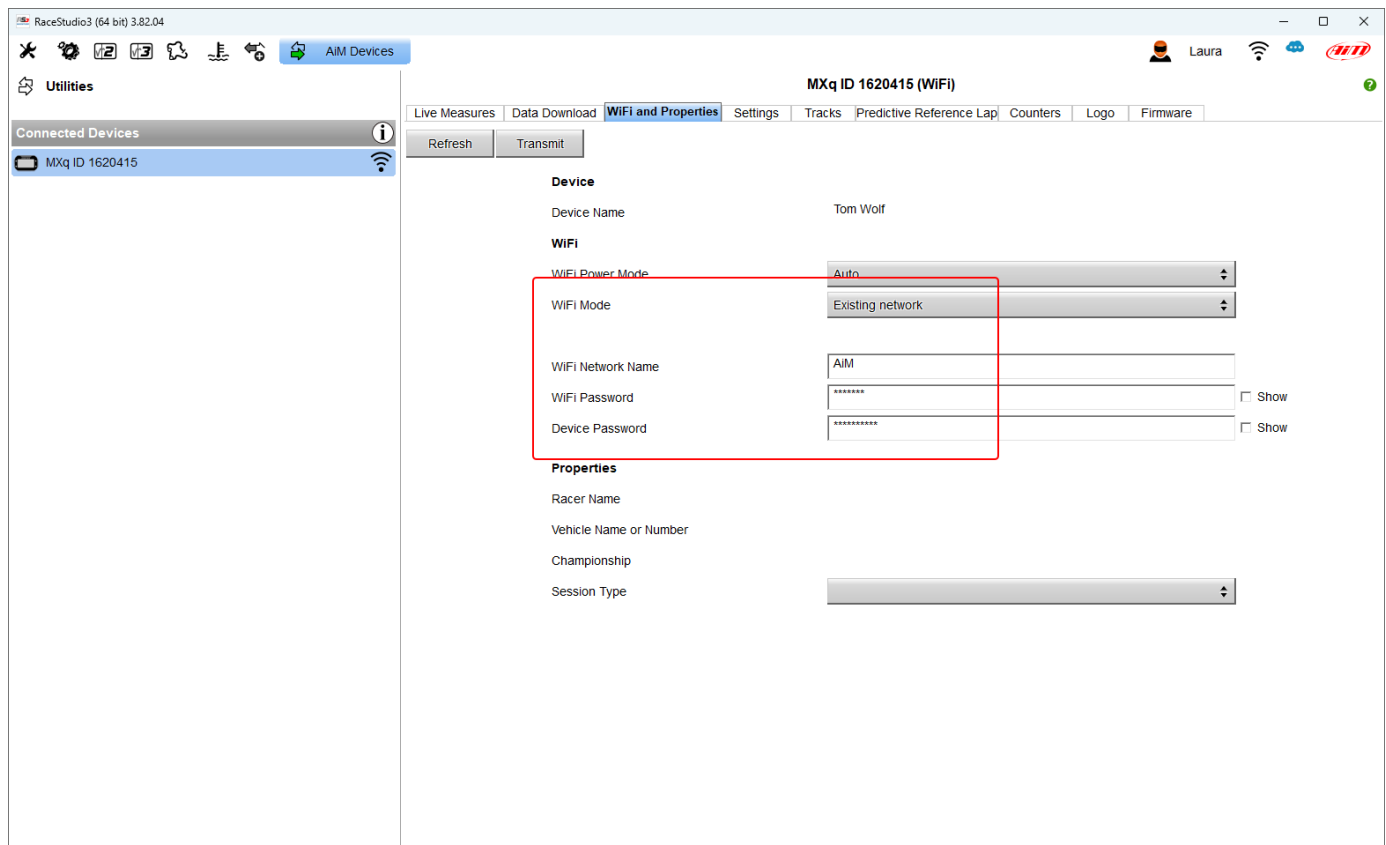



When the PC is authenticated to the network called "AiM" it can see all devices you configured to access the same network. In the image below three AiM devices are connected to the same "AiM" WLAN.

The screenshot shows the RaceStudio3 (64 bit) 3.82.04 interface. On the left, the 'Connected Devices' list under the 'AiM' network shows three devices: MXq ID 1620415, MXG-105, and Solo2-DL ID 7. The main window displays 'MXq ID 1620415 (WiFi)' with various data sections:

Live Measures			
LoggerTemp	108.5 F	External Voltage	13.7 V
VerticalAcc	-0.73 g	RollRate	-1.0 deg/s
Luminosity	1.81 %	PitchRate	3.6 deg/s
		InlineAcc	-0.64 g
		LateralAcc	-0.04 g
		YawRate	0.1 deg/s

ECU channels			
RPM	--- rpm	SPD	--- km/h
THR	--- #	TEMP	--- C
		GEAR	--- gear
		BRK	--- #

Calculated channels			
GPS LateralAcc	g	GPS InlineAcc	g
GPS Date	0000 y 00 m 00 d	GPS Yaw Rate	deg/s
		GPS Hours	0:00:00.000
		GPS Time	0 - 0
		Time - UNIX Time	315964800 s
		Time - UTC Time	0 s

GPS channels			
IGPS	GPS Good	IGPS - Altitude	614.63 ft
IGPS - Longitude	9.335332 E deg	IGPS - Heading	180.0 deg
		IGPS - Latitude	45.537779 N deg
IGPS - Speed	0.1 mph	IGPS - Pos Accur...	5 ft
		IGPS - Sat Number	13
		IGPS - Spd Accur...	0.4 mph

Lap channels			
Lap - Lap Number	0	Lap - Run Number	0
Lap Time	0:00.000	Lap - Split Number	0
		Lap - Split Time	0:00.000

## 6.1.4 – Wi-Fi network settings

In this chapter you find a short description of how to configure a WLAN including AiM devices and a PC. Here below is an example of configuration.

ROUTER SETTINGS	
Use this section to configure the internal network settings of your router. The IP Address that is configured here is the IP Address that you use to access the Web-based management interface. If you change the IP Address here, you may need to adjust your PC's network settings to access the network again.	
Router IP Address :	<input type="text" value="192.168.0.1"/>
Subnet Mask :	<input type="text" value="255.255.255.0"/>
Device Name :	<input type="text" value="Network_1"/>
Local Domain Name :	<input type="text"/> (optional)
Enable DNS Relay :	<input checked="" type="checkbox"/>

DHCP SERVER SETTINGS	
Use this section to configure the built-in DHCP Server to assign IP addresses to the computers on your network.	
Enable DHCP Server :	<input checked="" type="checkbox"/>
DHCP IP Address Range :	<input type="text" value="192.168.0.2"/> to <input type="text" value="192.168.0.6"/>
DHCP Lease Time :	<input type="text" value="10080"/> (minutes)
Always Broadcast :	<input checked="" type="checkbox"/> (compatibility for some DHCP Clients)
NetBIOS announcement :	<input type="checkbox"/>
Learn NetBIOS from WAN :	<input type="checkbox"/>
NetBIOS Scope :	<input type="text"/> (optional)
NetBIOS node type :	<input checked="" type="radio"/> Broadcast only (use when no WINS servers configured) <input type="radio"/> Point-to-Point (no broadcast) <input type="radio"/> Mixed-mode (Broadcast then Point-to-Point) <input type="radio"/> Hybrid (Point-to-Point then Broadcast)
Primary WINS IP Address :	<input type="text"/>
Secondary WINS IP Address :	<input type="text"/>

For better network performances, we suggest the use of a network device equipped with a DHCP server and using 3x3 MIMO technology like, for example a Linksys AS3200.

To maximize the bandwidth, you should not allow the Internet on this WLAN; this means the DHCP server should be configured without any DNS address nor gateway by default.



The parameters for the device network configuration in this example are:

- **Wireless network name: Network\_1**  
It means that the WLAN network name is "Network\_1." A PC has to be authenticated in this network to interact with any AiM device of this network.
- **Gateway address: 192.168.0.1**  
primary DNS server: 0.0.0.0  
secondary DNS server: 0.0.0.0  
(These settings prevent Internet connectivity on this WLAN.)
- **Subnet mask: 255.255.255.248**  
Enable DHCP server: yes  
DHCP IP address range: 192.168.0.2 to 192.168.0.6

These settings enable a DHCP server running on this WLAN and provide an IP address in a 2-6 range. This means that this network allows 5 network hosts.

The number of devices on a WLAN network depends on the subnet mask. Here below you see typical examples of network masks and IP addresses range.

The configuration in bold is the one we suggest (if a greater number of devices is not needed), being the one that makes it easier and quicker for RaceStudio 3 the identification of the devices in the network.

Subnet mask:	IP address range:	Number of devices:
255.255.255.0	192.168.0.1 – 254	254
255.255.255.128	192.168.0.1 – 126	126
255.255.255.192	192.168.0.1 – 62	62
255.255.255.224	192.168.0.1 – 30	30
255.255.255.240	192.168.0.1 – 14	14
<b>255.255.255.248</b>	<b>192.168.0.1 – 6</b>	<b>6</b>

## 6.1.5 – The Internet connectivity

---

For an optimal speed of your AiM device(s) we recommend not to allow the Internet on the same network and to set the WLAN in the same way.

You can of course allow the Internet access on your network but this would degrade the communication.

This slightly slower speed can be suitable for your needs but you can also have a second Wi-Fi connection using an additional hardware (NIC).

This configuration would provide an optimal speed of the data network of your AiM device(s) and at the same time would provide an internet connectivity with the second NIC.

## 6.1.6 – Connection issues

---

It can occur that your device is correctly connected to RaceStudio 3 via Wi-Fi but the software user interface does not show it. This may be because Wi-Fi port setting is set with a static IP. To switch it to dynamic (DHCP):

- open "Network and sharing centre" in the Windows™ research engine
- click on the Wi-Fi connection and a panel shows up
- select "Properties" option
- double click on "Internet Protocol version 4 (TCP/IPv4)"
- verify that option "Obtain an IP address" is active

For further information refer to FAQ section, Wi-Fi of [www.aim-sportline.com](http://www.aim-sportline.com).

## 6.1.7 – Working on Mac™ with virtualized Windows™

RaceStudio 3 only works on Windows™ operative systems; Mac users can use a virtualized Windows™ machine.

The main problem is that the host OS (Mac) must share its Wi-Fi interface with the virtualized operative system (Windows) as Ethernet interface and not as Wi-Fi interface.

### Configuring Parallels(™)

Select “Menu -> Configure...” in Parallels.

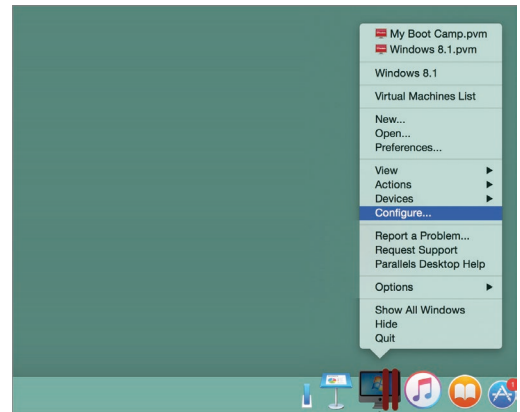

Press “Hardware” – top on the page that shows up – and select “Network” in the menu on the left.

Right on the configuration panel set "Type" field on “Wi-Fi”. Then select the device you want to communicate with.

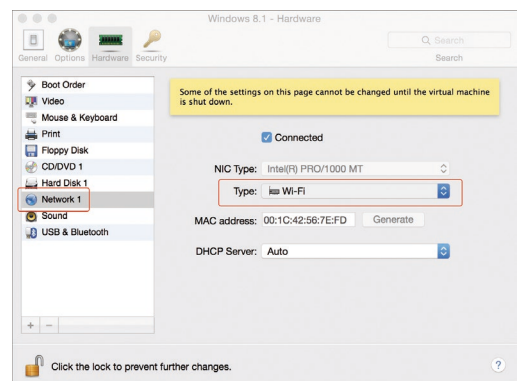

To ensure that the communication works select “Open Network preferences...” menu.



Verify that the status in the window that shows up is “Connected” and that the IP address associated is, for example, 10.0.0.10 (could be 10.0.0.11, 10.0.0.12, or generically 10.0.0.x).

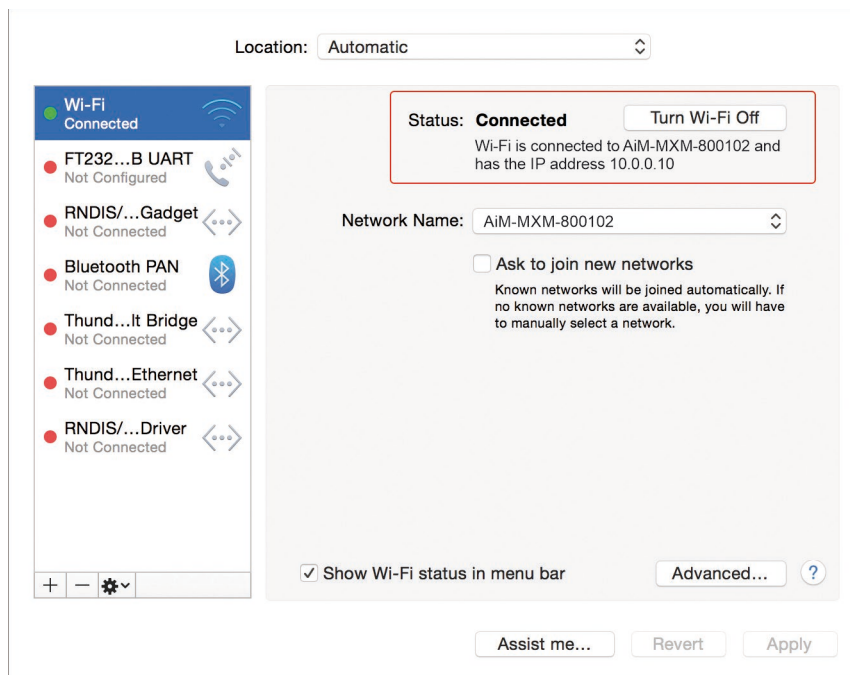

To enable RaceStudio 3 correctly working on a Mac with virtualized Windows™.

- press Wi-Fi icon
- select "Wi-Fi Settings" option CAMBIARE IMMAGINE

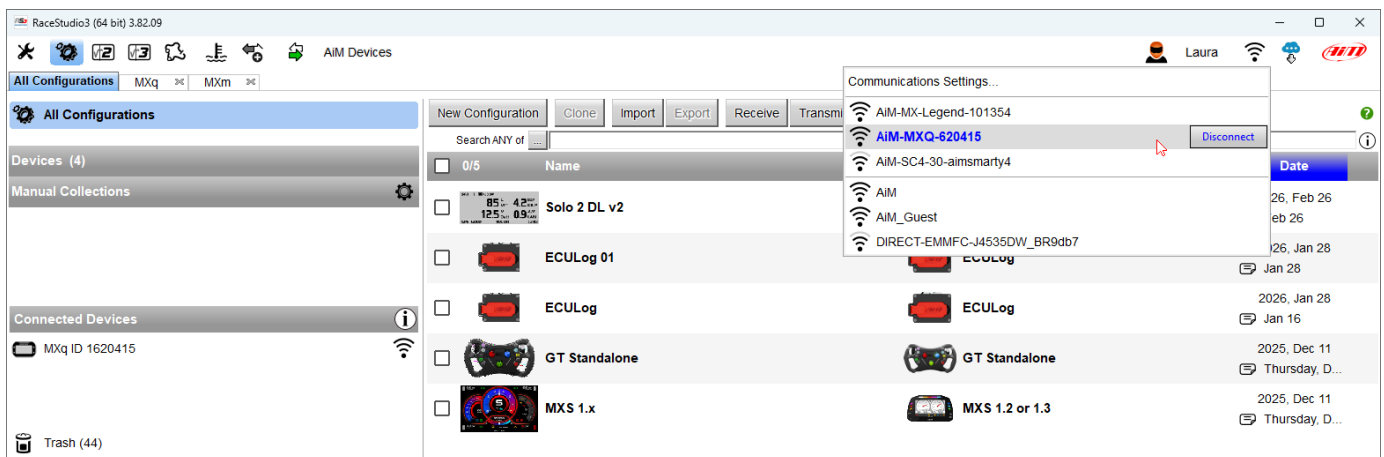

- enable the checkbox shown here below.

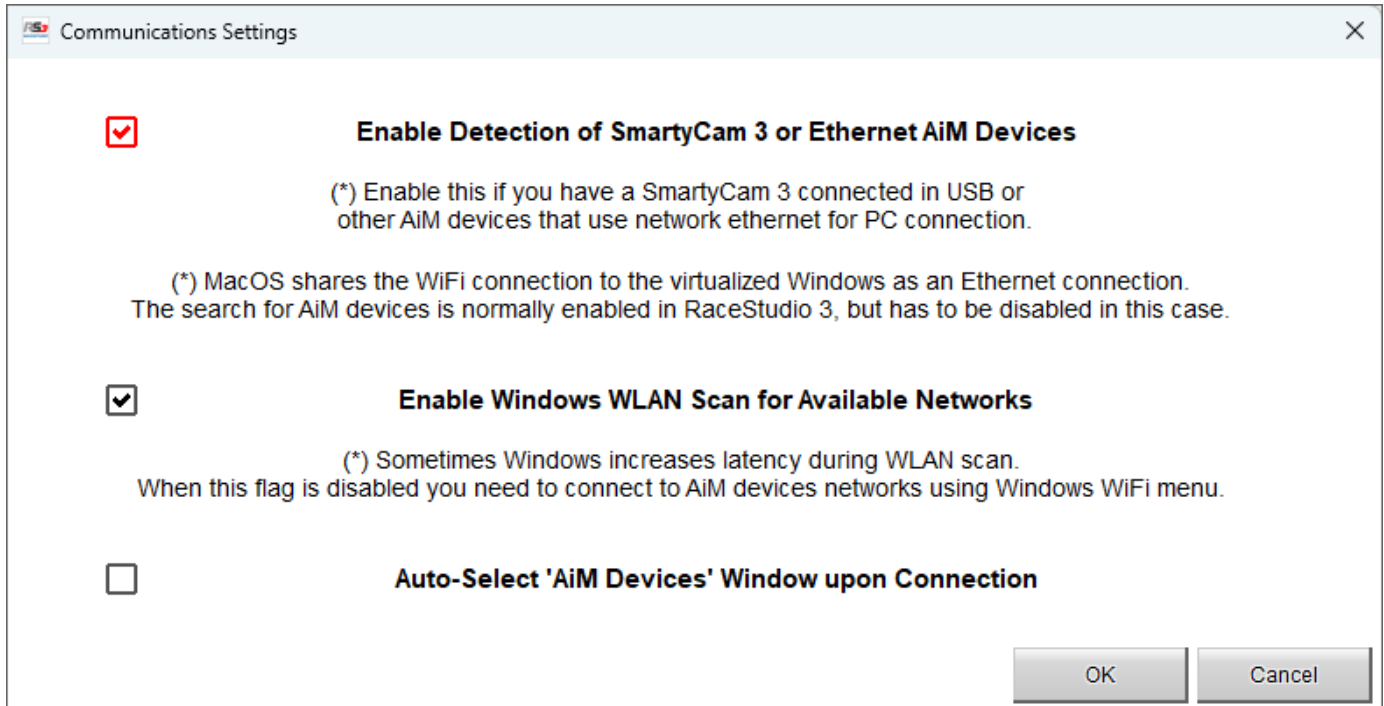

### 6.1.8 – Connected device visualization issues

It may occur that using RaceStudio 3 on an iMac with virtualized Windows the device connected via Wi-Fi takes some time to be shown in the network or is not shown at all. This is why we always suggest using an Wi-Fi (WLAN) router. This router work as an Access Point allowing more external devices to connect to its network. MXm Wi-Fi configuration is to be set on Existing Network as explained before.

## 6.2 – Configuration

Once MXm/MXq connected to the PC

- click “Configurations” icon and configurations page appears
- click “New” and new configuration panel appears: select “MXm” or “MXq” and press “OK”.

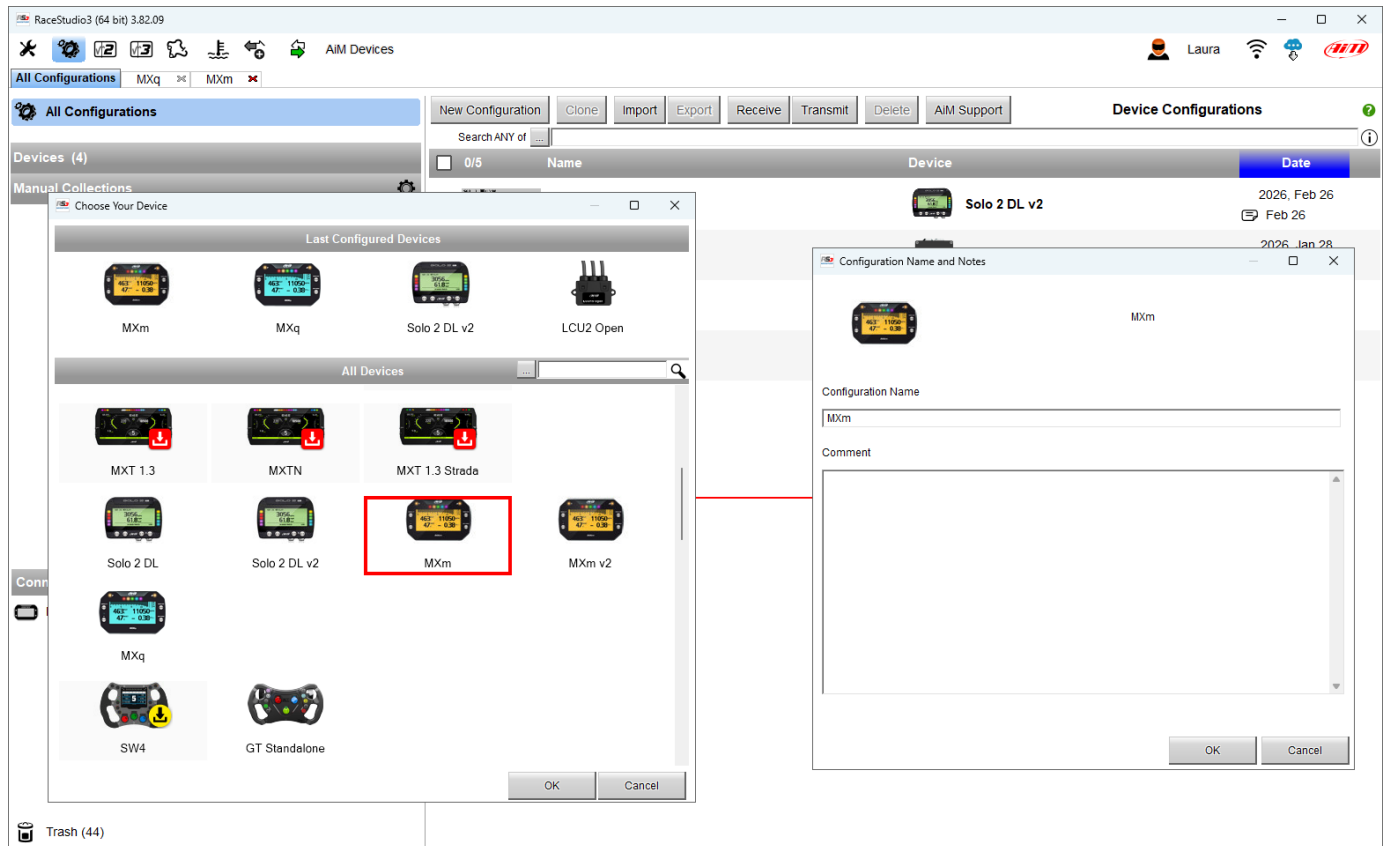



## 6.2.1 – Channels configuration

“Channels” layer is prompted. This tab is different depending on the logger you are configuring. To set a channel just click on its line and the related panel shows up. Speed Analog channels are disabled by default. First thing to do is enabling them.

The image below shows **MXm** tabs.

The screenshot shows the RaceStudio3 (64 bit) 3.82.09 interface. The 'Channels' tab is active, displaying a table of configured channels. The table has columns for ID, Name, Function, Sensor, Unit, Freq, and Parameters. Checkmarks in the 'Name' column indicate which channels are enabled.

ID	<input checked="" type="checkbox"/>	Name	Function	Sensor	Unit	Freq	Parameters
RPM	<input type="checkbox"/>	RPM	Engine RPM	RPM Sensor	rpm	20 Hz	max: 16000 ; factor: 1 ;
Spd1	<input type="checkbox"/>	Speed1	Speed	Speed Sensor	mph 0.1	20 Hz	wheel: 40.0 ; pulses: 1 ;
Spd2	<input type="checkbox"/>	Speed2	Speed	Speed Sensor	mph 0.1	20 Hz	wheel: 40.0 ; pulses: 1 ;
Ch01	<input checked="" type="checkbox"/>	Oil Temp	Oil Temperature	PT-100 2K (X05TRxxxA451xBPR F 0.1		20 Hz	
Ch02	<input type="checkbox"/>	Ch02	Voltage	Generic 0-5 V	mV	20 Hz	
Ch03	<input type="checkbox"/>	Ch03	Voltage	Generic 0-5 V	mV	20 Hz	
Ch04	<input type="checkbox"/>	Ch04	Voltage	Generic 0-5 V	mV	20 Hz	
Acc1	<input checked="" type="checkbox"/>	InlineAcc	Inline Acceleration	Internal Accelerometer	g 0.01	50 Hz	
Acc2	<input checked="" type="checkbox"/>	LateralAcc	Lateral Acceleration	Internal Accelerometer	g 0.01	50 Hz	
Acc3	<input checked="" type="checkbox"/>	VerticalAcc	Vertical Acceleration	Internal Accelerometer	g 0.01	50 Hz	
Gyr1	<input checked="" type="checkbox"/>	RollRate	Roll Rate	Internal Gyro	deg/s 0.1	50 Hz	
Gyr2	<input checked="" type="checkbox"/>	PitchRate	Pitch Rate	Internal Gyro	deg/s 0.1	50 Hz	
Gyr3	<input checked="" type="checkbox"/>	YawRate	Yaw Rate	Internal Gyro	deg/s 0.1	50 Hz	
PAccu	<input checked="" type="checkbox"/>	GPS PosAccuracy	AIM GPS Position Accuracy	GPS	ft	auto (accor...	
Spd	<input checked="" type="checkbox"/>	GPS Speed	GPS Speed	GPS	mph 0.1	auto (accor...	
Alt	<input checked="" type="checkbox"/>	Altitude	GPS Altitude	GPS	ft 0.01	auto (accor...	
OdD	<input checked="" type="checkbox"/>	Odometer	Odometer Total	Odometer	mi 0.1	auto (event f...	
Luma	<input checked="" type="checkbox"/>	Luminosity	Brightness	Luminosity	% 0.01	1 Hz	
Fuel	<input type="checkbox"/>	FuelUsed	Fuel Level	Fuel Used	l 0.1	10 Hz	
LogT	<input checked="" type="checkbox"/>	LoggerTemp	Device Temperature	Logger Temperature	F	1 Hz	
POTCA	<input type="checkbox"/>	POTotCrntAll	Output Current	Internal Math Channel	A 0.1	10 Hz	

To set **Speed** channels click on the row and a setting panel appears. In addition to sampling frequency, unit of measure and display parameters, you can choose:

- Function: Vehicle speed, Angular velocity, Speed, Turbo RPM
- Sensor: Speed sensor or ABS speed
- Speed parameters in the proper bottom box

**Please note:** setting one speed as ABS Speed both of them switch to ABS speed as shown here below.

ID	Name	Function	Sensor	Unit	Freq	Parameters	
RPM	<input type="checkbox"/> RPM	Engine RPM	RPM Sensor	rpm	20 Hz	max: 16000 ; factor: f1 ;	
Spd1	<input checked="" type="checkbox"/> Speed1	Speed	ABS speed sensor	mph 0.1	20 Hz	wheel: 65.0 ; pulses: 1 ;	
Spd2	<input checked="" type="checkbox"/> Speed2	Speed	ABS speed sensor	mph 0.1	20 Hz	wheel: 65.0 ; pulses: 1 ;	
Ch01	<input checked="" type="checkbox"/> Oil Temp	Oil Temperature	PT-100 2k (X051Rxxx451xBPR F 0.1		20 Hz		
Ch02	<input type="checkbox"/> Ch02	Channel Settings					
Ch03	<input type="checkbox"/> Ch03	Name	Speed2			20 Hz	
Ch04	<input type="checkbox"/> Ch04	Function	Vehicle Spd			20 Hz	
Acc1	<input checked="" type="checkbox"/> InlineAcc				50 Hz		
Acc2	<input checked="" type="checkbox"/> LateralAcc				50 Hz		
Acc3	<input checked="" type="checkbox"/> VerticalAcc	Sensor	ABS speed sensor			50 Hz	
Gyr1	<input checked="" type="checkbox"/> RollRate	Sampling Frequency	20 Hz			50 Hz	
Gyr2	<input checked="" type="checkbox"/> PitchRate	Unit of Measure	kmh			50 Hz	
Gyr3	<input checked="" type="checkbox"/> YawRate	Display Precision	1 decimal place			50 Hz	
PAccu	<input checked="" type="checkbox"/> GPS PosAc	Speed Parameters					auto (accor...
Spd	<input checked="" type="checkbox"/> GPS Speed	Wheel circumference	[mm]	1600		auto (accor...	
Alt	<input checked="" type="checkbox"/> Altitude	Pulse per wheel revolution		1		auto (accor...	
OdD	<input checked="" type="checkbox"/> Odometer					auto (eventf...	
Luma	<input checked="" type="checkbox"/> Luminosity					1 Hz	
Fuel	<input type="checkbox"/> FuelUsed					10 Hz	
LogT	<input checked="" type="checkbox"/> LoggerTem					1 Hz	
POTCA	<input type="checkbox"/> POTCrtA					10 Hz	

To set the four **Analog channels** click on the related row, a setting panel appears and you can choose function, sensor type, measure units, display precision or specific parameters.

The image below shows **MXq** channels tab. It only features one channel disabled by default. First of all enable it. To set MXq channel:

- Click on the channel
- The corresponding setting panel is prompted
- Here you can set Function and Sensor type, Sampling frequency and Unit of Measure

The screenshot shows the RaceStudio3 (64 bit) 3.82.09 interface. The 'Channels' tab is active, displaying a list of channels. The 'Ch' channel is selected, and its settings panel is open. The settings panel shows the following configuration:

ID	Name	Function	Sensor	Unit	Freq	Parameters
RPM1	<input checked="" type="checkbox"/> RPM	Engine RPM	RPM Sensor	rpm	20 Hz	max:16000; factor:1;
Ch	<input checked="" type="checkbox"/> Ch	Voltage	Generic 0-5 V	mV	20 Hz	
Acc1	<input checked="" type="checkbox"/> InlineAcc	Inline Acceleration	Internal Accelerometer	g 0.01	50 Hz	
Acc2	<input checked="" type="checkbox"/> LateralAcc	Lateral Acceleration	Internal Accelerometer	g 0.01	50 Hz	
Acc3	<input checked="" type="checkbox"/> VerticalAcc	Vertical Acceleration	Internal Accelerometer	g 0.01	50 Hz	
Gyr1	<input checked="" type="checkbox"/> RollRate	Roll Rate	Internal Gyro	deg/s 0.1	50 Hz	
Gyr2	<input checked="" type="checkbox"/> PitchRate	Pitch Rate	Internal Gyro	deg/s 0.1	50 Hz	
Gyr3	<input checked="" type="checkbox"/> YawRate	Yaw Rate	Internal Gyro	deg/s 0.1	50 Hz	
PAccu	<input checked="" type="checkbox"/> GPS PosAccuracy	GPS Position Accuracy	GPS	m	1 Hz	
Spd	<input checked="" type="checkbox"/> GPS Speed	GPS Speed	GPS	m/s	1 Hz	
Alt	<input checked="" type="checkbox"/> Altitude	Altitude	GPS	m	1 Hz	
OdD	<input checked="" type="checkbox"/> Odometer	Odometer	GPS	m	1 Hz	
Luma	<input checked="" type="checkbox"/> Luminosity	Luminosity	Light	lux	1 Hz	
Fuel	<input type="checkbox"/> FuelUsed	Fuel Used	Fuel	liters	1 Hz	
LogT	<input checked="" type="checkbox"/> LoggerTemp	Logger Temperature	Temperature	°C	1 Hz	
POTCA	<input type="checkbox"/> POTCmtAll	POTCmtAll	POTCmtAll	°C	10 Hz	

The 'Channel Settings' dialog box for the 'Ch' channel is open, showing the following settings:

- Name: Ch
- Function: Voltage
- Sensor: Generic 0-5 V
- Sampling Frequency: 20 Hz
- Unit of Measure: mV

## 6.2.2 – ECU Connection and configuration

MXm and MXq can be connected to your vehicle ECU. When possible documents explaining how to connect your device to the vehicle ECU are published on our website [www.aim-sportline.com](http://www.aim-sportline.com). As explained, AiM devices can communicate using all currently available communication lines: CAN, RS232, K-Line.

To load the ECU protocol in the configuration:

- enter “ECU Stream” tab
- press “Change ECU” button
- select ECU Manufacturer and ECU Model (in the example FORD/ MUSTANG 2010)
- press OK

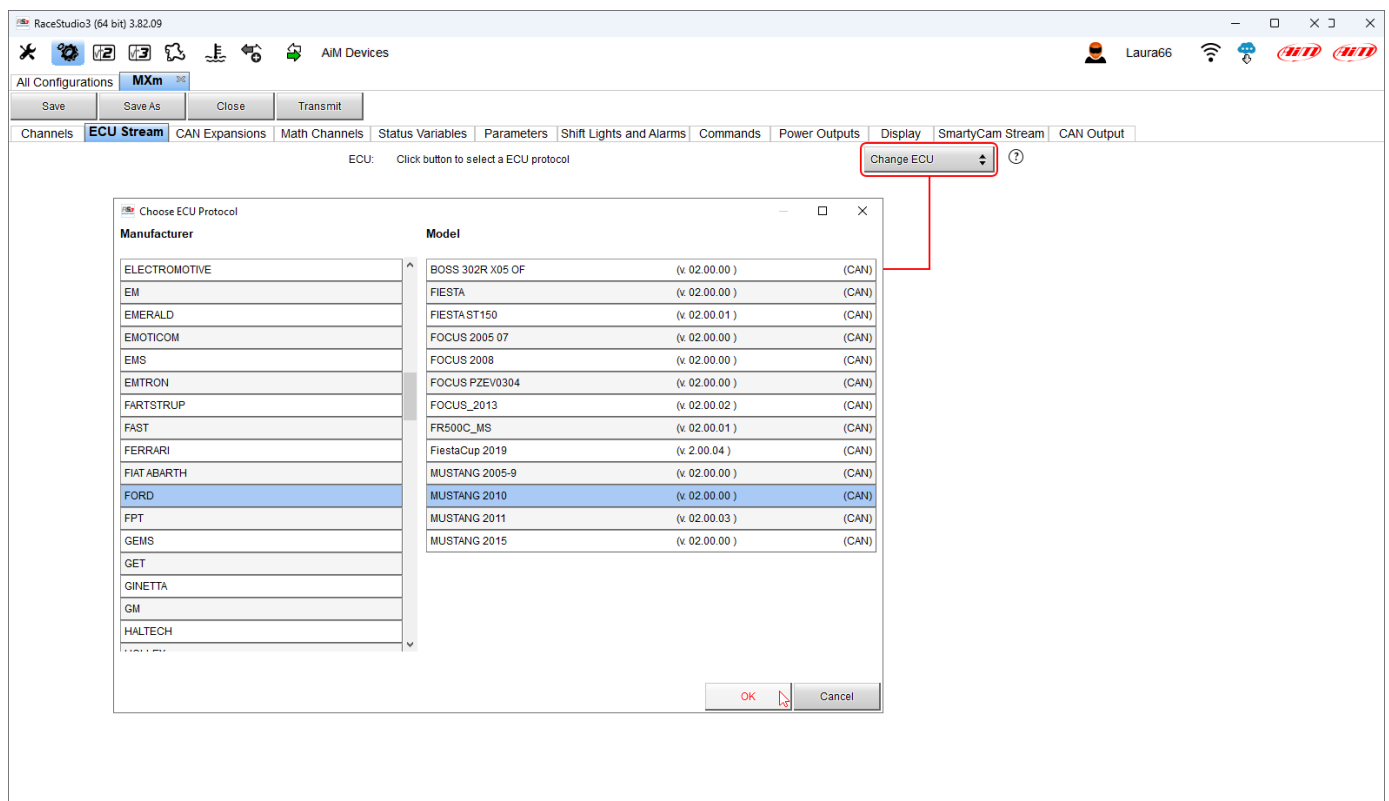

### 6.2.3 – AiM CAN Expansions configurations

MXm and MXq can be connected to a lot of AiM CAN Expansions. To do so:

- press “New Expansion” button in CAN Expansion tab
- select the CAN expansion you need to connect
- press “OK”
- the related setting panel is prompted
- set it;

**Please refer to each expansion user manual to know how to set it.** Moreover in the following page a table shows you which CAN Expansions are supported by MXm/MXq.

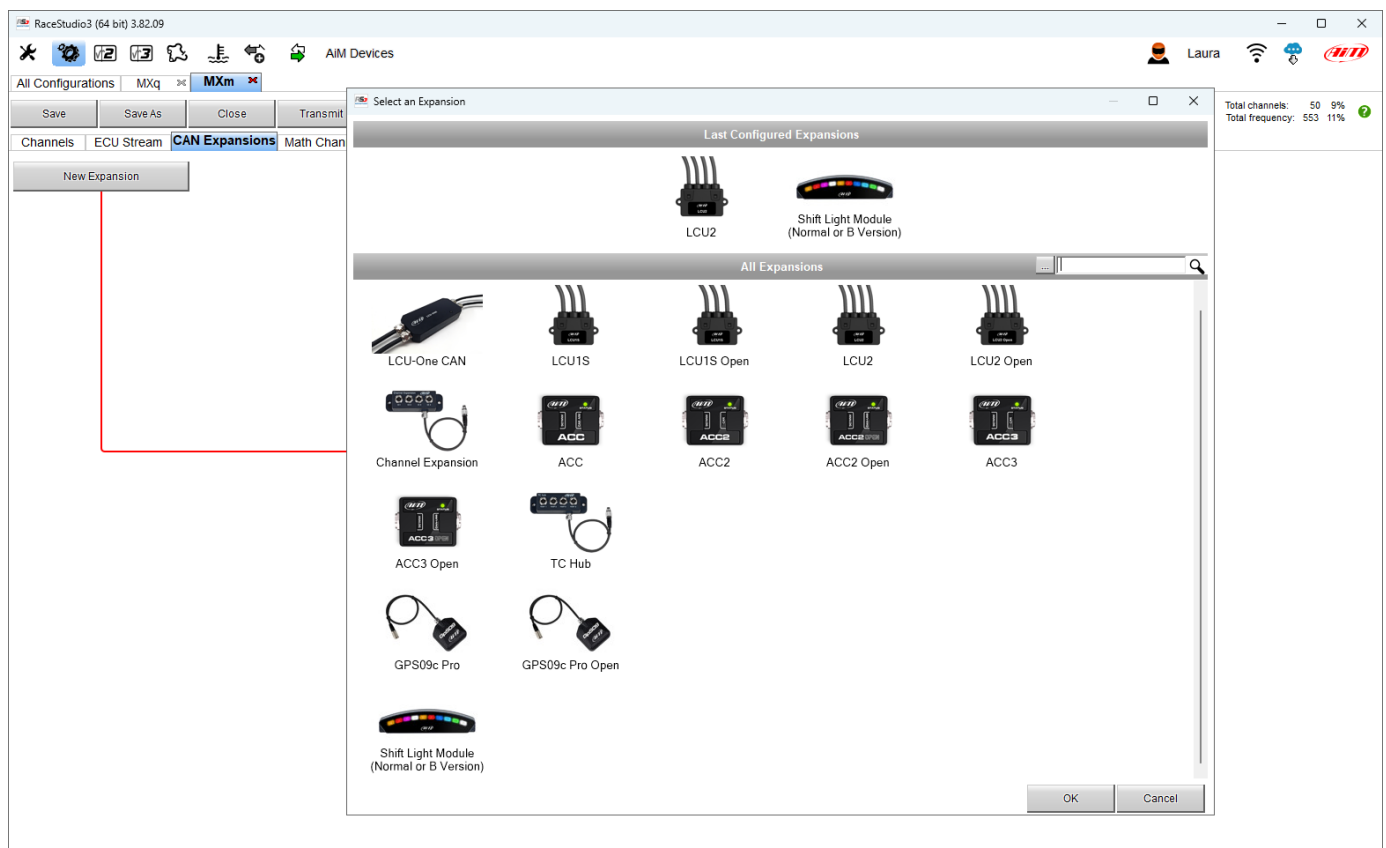



The table below shows AiM CAN Expansions supported by MXm/MXq.

<b>AiM CAN Expansion</b>	<b>MXm</b>	<b>MXq</b>
LCU-One CAN	✓	✓
LCU1S	✓	✓
LCU1S Open	✓	✓
LCU2	✓	✓
LCU2 Open	✓	✓
Channel Expansion	✓	✓
ACC	✓	✓
ACC2 Open	✓	✓
ACC3	✓	✓
ACC3 Open	✓	✓
Tc Hub	✗	✗
GPS09c Pro	✓	✓
GPS09c Pro Open	✓	✓
Shift Light Module (Normal or B Version)	✗	✗

## 6.2.4 – Math channels

Here you can create math channels; available options are:

- Bias: considering a relation between two mutually compatible channels it computes which one is prevailing (typically used for suspensions or brakes);
- Bias with threshold: it needs the user to set a threshold value for the considered channels; once these threshold values are both exceeded the system makes the calculation;
- Calculated gear: it calculates the gear position using engine RPM and vehicle speed
- Precalculated gear: it calculates the gear position using Load/Shaft ratio for each gear and for the vehicle axle too
- Linear correction: typically used when a channel is not available in the desired format or if it is wrongly tuned and cannot be tuned again
- Simple operation: it adds or subtract from a channel value another channel value or a constant value
- Division Integer: gets the integer part of the division
- Division Modulo: gets the remainder part of the division
- Bit Composed: composes 8 flags in a bit-field measure
- Blinkers hazard: calculates the blinking status of the turning signals and of the hazard

Each option asks the user to fill in a proper panel.

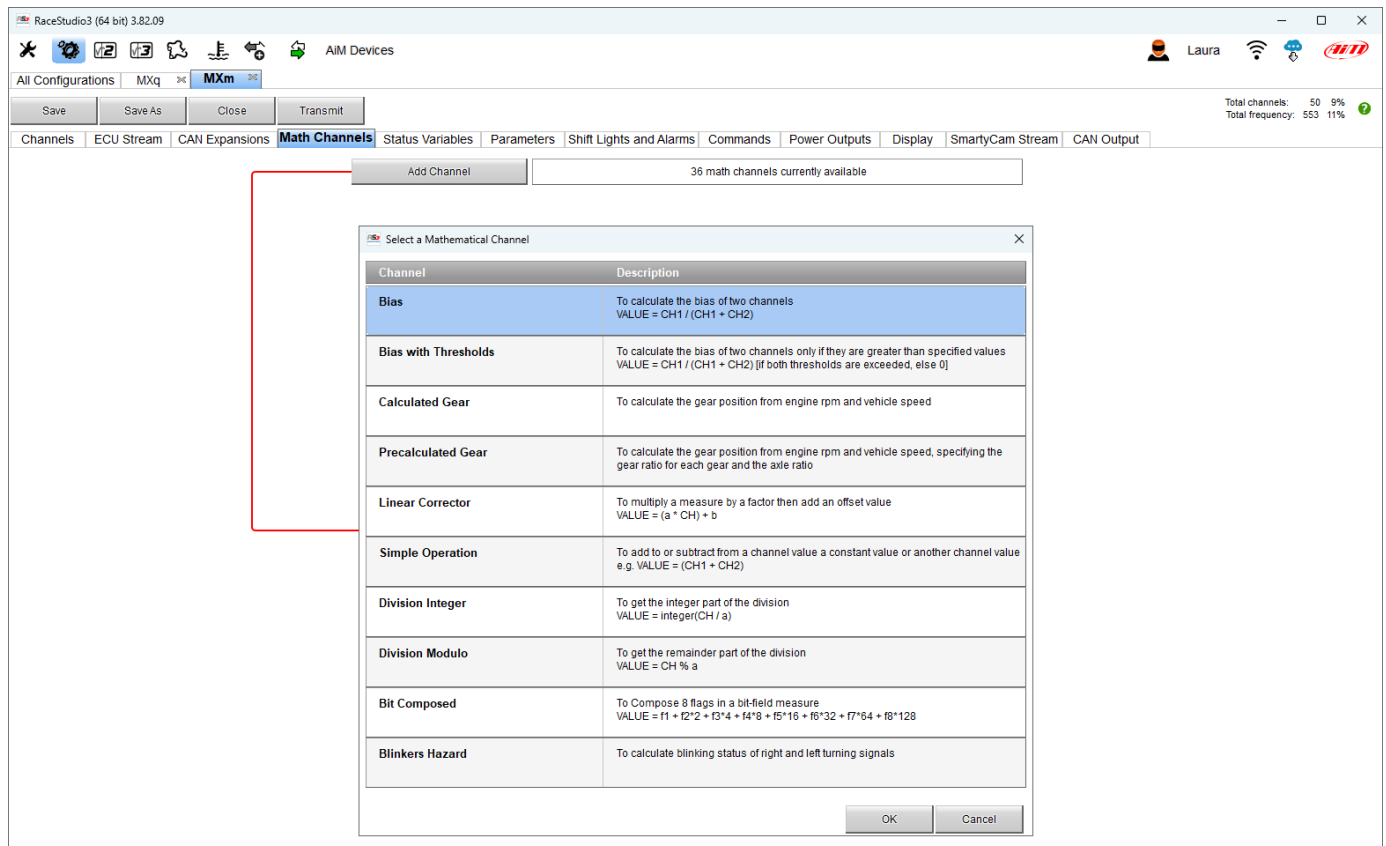

The screenshot shows the 'RaceStudio3 (64 bit) 3.82.09' application window. The 'Math Channels' tab is active, showing a list of 36 available math channels. A dialog box titled 'Select a Mathematical Channel' is open, displaying the following options:

Channel	Description
<b>Bias</b>	To calculate the bias of two channels VALUE = CH1 / (CH1 + CH2)
<b>Bias with Thresholds</b>	To calculate the bias of two channels only if they are greater than specified values VALUE = CH1 / (CH1 + CH2) [if both thresholds are exceeded, else 0]
<b>Calculated Gear</b>	To calculate the gear position from engine rpm and vehicle speed
<b>Precalculated Gear</b>	To calculate the gear position from engine rpm and vehicle speed, specifying the gear ratio for each gear and the axle ratio
<b>Linear Corrector</b>	To multiply a measure by a factor then add an offset value VALUE = (a * CH) + b
<b>Simple Operation</b>	To add to or subtract from a channel value a constant value or another channel value e.g. VALUE = (CH1 + CH2)
<b>Division Integer</b>	To get the integer part of the division VALUE = integer(CH / a)
<b>Division Modulo</b>	To get the remainder part of the division VALUE = CH % a
<b>Bit Composed</b>	To Compose 8 flags in a bit-field measure VALUE = f1 + f2*2 + f3*4 + f4*8 + f5*16 + f6*32 + f7*64 + f8*128
<b>Blinkers Hazard</b>	To calculate blinking status of right and left turning signals

## 6.2.5 – Status variables setting

Status variables are user defined conditions that can be used in different situations. This means that when setting alarms in “Shift lights and Alarm” page you can set different alarms including the same condition (status variable) simply recalling it from the list. The status variable can also be logged checking “Log values” checkbox thereby working as an analog channel. Pressing “Add New Variable” the related panel appears.

The screenshot shows the RaceStudio3 interface with the "Status Variables" tab selected. A dialog box titled "Status Variable Settings" is open, allowing configuration of a new status variable. The "Log values" checkbox is highlighted with a red box. The "Name" field is also highlighted with a red box. The dialog includes options for "Same condition for activation and deactivation", "Work As" (Momentary, Toggle, Multistatus), "Use timing" (Time threshold between short and long status: 0.5 sec), and "Generate Square Wave". It also features three tables for Rest Status, Active Status, and Long Status, each with Label and Value columns. The Rest Status table has S0 and 0, Active Status has S1 and 1, and Long Status has S2 and 2. Below these are "Activated" and "Deactivated" conditions with "for at least" time settings (0 sec). A list box at the bottom contains "Always FALSE" and an "Add" button. A red error message "Name field cannot be empty" is visible at the bottom of the dialog. The "Save" and "Cancel" buttons are at the bottom right.

To set this panel you need to set different parameters. To say:

- Fill in status variable name (1)
- Set sampling frequency through the drop down menu (2)
- Set the activation/deactivation condition (3); available options are:
  - Same condition for activation and deactivation
  - Distinct condition for activation and deactivation
  - Multiple output values each with its own condition
- Status variable working mode (all usable with timing 4); available options are: Momentary, Toggle and Multistatus, that means:
  - **Momentary**: the channel is active when the pushbutton is pressed and comes back to “Not Active” status when the button is released
  - **Toggle**: the channel status switches from ON to OFF each time the button is pressed
  - **Multistatus**: the channel can have different statuses according to the number of pressures and it is possible to add/remove statuses
- Condition to link to the Status Variable (5)
- Possibility to generate a Square Wave (with Momentary and Toggle working mode only – 6)

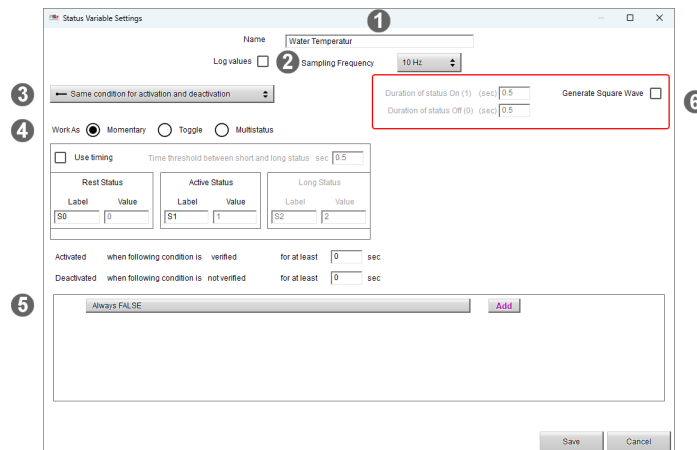

The screenshot shows the 'Status Variable Settings' dialog box. It contains the following elements:

- 1**: Name field containing 'Water Temperatur'.
- 2**: Sampling Frequency dropdown menu set to '10 Hz'.
- 3**: Activation/Deactivation condition dropdown menu set to 'Same condition for activation and deactivation'.
- 4**: Working mode radio buttons: 'Momentary' (selected), 'Toggle', and 'Multistatus'.
- 5**: 'Use timing' checkbox (unchecked) and a 'Time threshold between short and long status' field set to '0.5'.
- 6**: A red box highlights the 'Duration of status On (1)' and 'Duration of status Off (0)' fields, both set to '0.5', and the 'Generate Square Wave' checkbox (unchecked).
- Below the timing section, there are three tables for 'Rest Status', 'Active Status', and 'Long Status', each with 'Label' and 'Value' columns.
- At the bottom, there are 'Activated' and 'Deactivated' conditions with 'verified/not verified' and 'for at least' time fields.
- A list box at the bottom contains 'Always FALSE' and an 'Add' button.
- 'Save' and 'Cancel' buttons are at the bottom right.

## Same condition for activation/deactivation conditions

- Select "Same condition for activation and deactivation" in the drop down menu (1)
- Click the button to specify a condition (2)
- Select custom condition option (3)
- Select the channel to use ( ECU Water temperature in the example 4)
- Press "OK" (5)
- The condition is shown in the condition panel (6)
- Press "Add" and the condition is shown in the setting panel (7)
- Press Save (8)

**1** Status Variable Settings

Name: Water Temperatur  
 Log values:  Sampling Frequency: 10 Hz  
 Duration of status On (1) (sec): 0.5  
 Duration of status Off (0) (sec): 0.5  
 Generate Square Wave:

Work As:  Momentary  Toggle  Multistatus

Use timing:  Time threshold between short and long status: sec: 0.5

Rest Status		Active Status		Long Status	
Label	Value	Label	Value	Label	Value
S0	0	S1	1	S2	2

Activated when following condition is verified for at least 0 sec  
 Deactivated when following condition is not verified for at least 0 sec

**2** Always FALSE **Add**

**3** Condition

Always TRUE  Always FALSE

RPM [MXm-ECU] greater than constant rpm 1000

TRUE after a time of 0 sec in which it is verified FALSE after a time of 0 sec in which it is no longer verified

**4** Select Channel

Device	Type	Channel
Main Device - MXm	ECU	RPM
	Lap Channels	SpeedVeh
	GPS	SpeedFL
	Accelerometer	SpeedFR
	Gyro	SpeedRL
	Odometer	SpeedRR
	Start Recording Condition	Gear
	Internal	WaterTemp
	Battery Channels	TurboBoost
		TCSBrakeEvent
		TCSEngEvent
		StabChITaltal
		StabChIMTXT
		TyreRMile
		FuelLevelMean
		FuelInst1
		FuelInst2
		AirRatio
		PedalPosition

**5** OK Cancel

**6** Condition

Always TRUE  Always FALSE

WaterTemp [MXm-ECU] greater than constant F 194

TRUE after a time of 5 sec in which it is verified FALSE after a time of 5 sec in which it is no longer verified

**7** WaterTemp [MXm-ECU] greater than 194 F (TRUE after 5 sec; FALSE after 5 sec) **Add**

**8** Save Cancel

The condition is shown in "Status Variable" tab. Mousing over the Status Variable it is possible to edit and/or delete it.

The screenshot displays the RaceStudio3 interface with the "Status Variables" tab selected. A table on the left lists status variables, with "Water Temperatur" highlighted and its frequency "10 Hz" circled in red. The main panel shows the configuration for "Water Temperatur":

- Name: Water Temperatur
- Log values:
- Sampling Frequency: 10 Hz
- Condition: Same condition for activation and deactivation
- Duration of status On (1) (sec): 0.5
- Duration of status Off (0) (sec): 0.5
- Generate Square Wave:
- Work As:  Momentary,  Toggle,  Multistatus
- Use timing:  Time threshold between short and long status: sec 0.5
- Rest Status: Label S0, Value 0
- Active Status: Label S1, Value 1
- Long Status: Label S2, Value 2

Activation and deactivation conditions are defined as follows:

It is activated (ON) when:  
( WaterTemp [MXq-ECU] greater than 194 F (TRUE after 5 sec; FALSE after 5 sec) )  
is verified

It is deactivated (OFF) when:  
it is not verified

### Distinct conditions for activation and deactivation.

- select this condition in the drop down menu
- the panel allows to set the two conditions; set mode is the same described for the option “Same condition for activation and deactivation”
- save the conditions

Status Variable Settings

Name:

Log values  Sampling Frequency:

**Distinct conditions for activation and deactivation**

Duration of status On (1) (sec):  Generate Square Wave

Duration of status Off (0) (sec):

WorkAs:  Momentary  Toggle  Multistatus

Use timing Time threshold between short and long status sec:

Rest Status		Active Status		Long Status	
Label	Value	Label	Value	Label	Value
<input type="text" value="S0"/>	<input type="text" value="0"/>	<input type="text" value="S1"/>	<input type="text" value="1"/>	<input type="text" value="S2"/>	<input type="text" value="2"/>

Activated when following condition is verified for at least  sec

WaterTemp [MXm-ECU] greater than 194 F (TRUE after 5 sec; FALSE after 5 sec)

Deactivated when following condition is verified for at least  sec

WaterTemp [MXm-ECU] less than 194 F (TRUE after 5 sec; FALSE after 5 sec)

### Multiple output values each with its own condition.

- select this condition in the drop down menu
- the panel allows to set the two conditions together (and) or alternative (Or); set mode is the same described for the option “Same condition for activation and deactivation”
- save the conditions

## 6.2.6 – Parameters settings

Parameters page is divided in three parts.

- on top **Lap Detection** parameters; mousing over the question marks a pop up message explains the working mode of:
  - hold lap time for: the time period for which lap time is shown on MXm /MXq display
  - the track width: width that will be considered for any GPS point you set
- central **Reference speed**: here it is possible to decide which speed to use as reference one among these available; default setting is GPS Speed.
- bottom **Start data recording** conditions;
  - standard conditions (default setting) make the system start recording when RPM is greater than 850 or speed (not GPS) is higher than 6 mph and switches Wi-Fi off
  - custom conditions: you can set two conditions and decide if making MXm/MXq start recording when only one of them is reached (“OR”) or when both are satisfied (“AND”); click on the row corresponding to the custom condition and set it.

The screenshot shows the RaceStudio3 (64 bit) 3.82.09 interface. The 'Parameters' tab is active. The 'Lap Detection' section includes:

- Hold lap time for 8 sec (help icon: This is the number of seconds that the lap time is held static on the display before resuming a dynamic views such as: predictive, current or running lap time)
- GPS Beacon (help icon: This is the width that will be considered for any GPS points set(i.e. the width of the start/finish line))
- Track Width 33 ft (help icon: This is the width that will be considered for any GPS points set(i.e. the width of the start/finish line))
- CAN Optical Beacon (help icon: After receiving an IR lap signal, the receiver cannot receive another signal for how ever many seconds specified. This is used to ignore additional signals from other possible beacon sources)

The 'Reference Speed' section has:

- Select the channel to use as reference speed: GPS Speed [MXq-GPS]

The 'Start Data Recording' section has:

- Standard Conditions: Recording starts when RPM is greater than 850 or speed (not GPS) is greater than 6 mph
- Custom Conditions: Recording starts when following condition is verified for at least 0 sec
  - AND
    - GPS Speed [MXq-GPS] greater than 10 mph (TRUE after 1 sec; FALSE after 1 sec) [Add]
    - RPM [MXq-ECU] greater than 900 rpm (TRUE after 1 sec; FALSE after 1 sec) [Add]

## 6.2.7 – Shift Lights and Alarms

In this page you can set:

- shift lights (on top): they can be used for predictive time or as gear shift lights (default)
- alarm led (bottom)

The screenshot shows the 'Shift Lights and Alarms' configuration page in RaceStudio3. At the top, there are radio buttons for 'Use for predictive time' (unselected) and 'Use as gear shift lights' (selected). Below this is a table for configuring shift lights:

Gear	Shift Light 1	2	3	4	5
All	9200	9400	9600	9800	10000

Each cell in the table contains a small colored circle representing the light's state. Below the table is an 'Activate Simulation' checkbox (unchecked). In the center is a large image of the MXm device display, which shows a tachometer scale from 0 to 10,000 RPM. The current RPM is 11050. Other displayed values include 463 EGT, 47 WAT, and -0.38 PT. At the bottom, there is an 'Add New Alarm' button and a status bar indicating '34 alarms currently available'.

**Use as gear Shift Lights** To use the led bar as shift lights click the setting icon (⚙️) and the related panel shows up. You can

- import/export shift lights setting using the proper buttons
- decide the sequence mode of the LEDs enabling the desired option:
  - a LED stays on if its threshold is exceeded
  - a LED stays on until another LED with higher threshold is turned on or
- link the shift lights to the engaged gear enabling the related checkbox; in this last case you need to fill in max gear number and set LEDs colours and threshold values for each gear.

The screenshot shows the RaceStudio3 interface with the 'Shift Lights and Alarms' configuration panel. The main dashboard displays the following values:

- RPM: 11050
- EGT: 463
- WAT: 47
- PT+: -0.38

The 'Shift Lights Options' dialog box is open, showing the following configuration:

- Use for predictive time:**  (Unselected)
- Use as gear shift lights:**  (Selected)
- Sequence mode:**
  - ALED stays on if its threshold is exceeded
  - ALED stays on until another LED with higher threshold is turned on
- Engine rpm channel:** RPM [MXm-ECU]
- Gear dependent shift lights:**  (Selected)
- Max gear number:** 6
- Gear channel:** Gear [MXm-ECU]

The 'Select colors and threshold values for shift lights' table is as follows:

Gear	Shift Light 1	2	3	4	5	
6	9200	9400	9600	9800	10000	[Icons]
5	9200	9400	9600	9800	10000	[Icons]
4	9200	9400	9600	9800	10000	[Icons]
3	9200	9400	9600	9800	10000	[Icons]
2	9200	9400	9600	9800	10000	[Icons]
1	9200	9400	9600	9800	10000	[Icons]

**Use for predictive time.** To use the LED bar for predictive lap time enable the related option and press the setting icon (⚙️).  
You can

- import/export shift lights setting using the proper buttons
- decide the sequence mode of the LEDs enabling the desired option:
  - a LED stays on if its threshold is exceeded
  - a LED stays on until another LED with higher threshold turns on or
- fill in the predictive time increment of each LED and set the LEDs colours. The LED value indicates the time gap to be assigned to each LED. With reference to the image below, assuming you fill in "0.1" and your lap time is improving of 0.3 sec toward the reference lap, your logger will switch on 3 LEDs green; if, on the contrary, your lap time is worsening the LEDs will switch on red. The lap considered as reference is the best one of the current session.

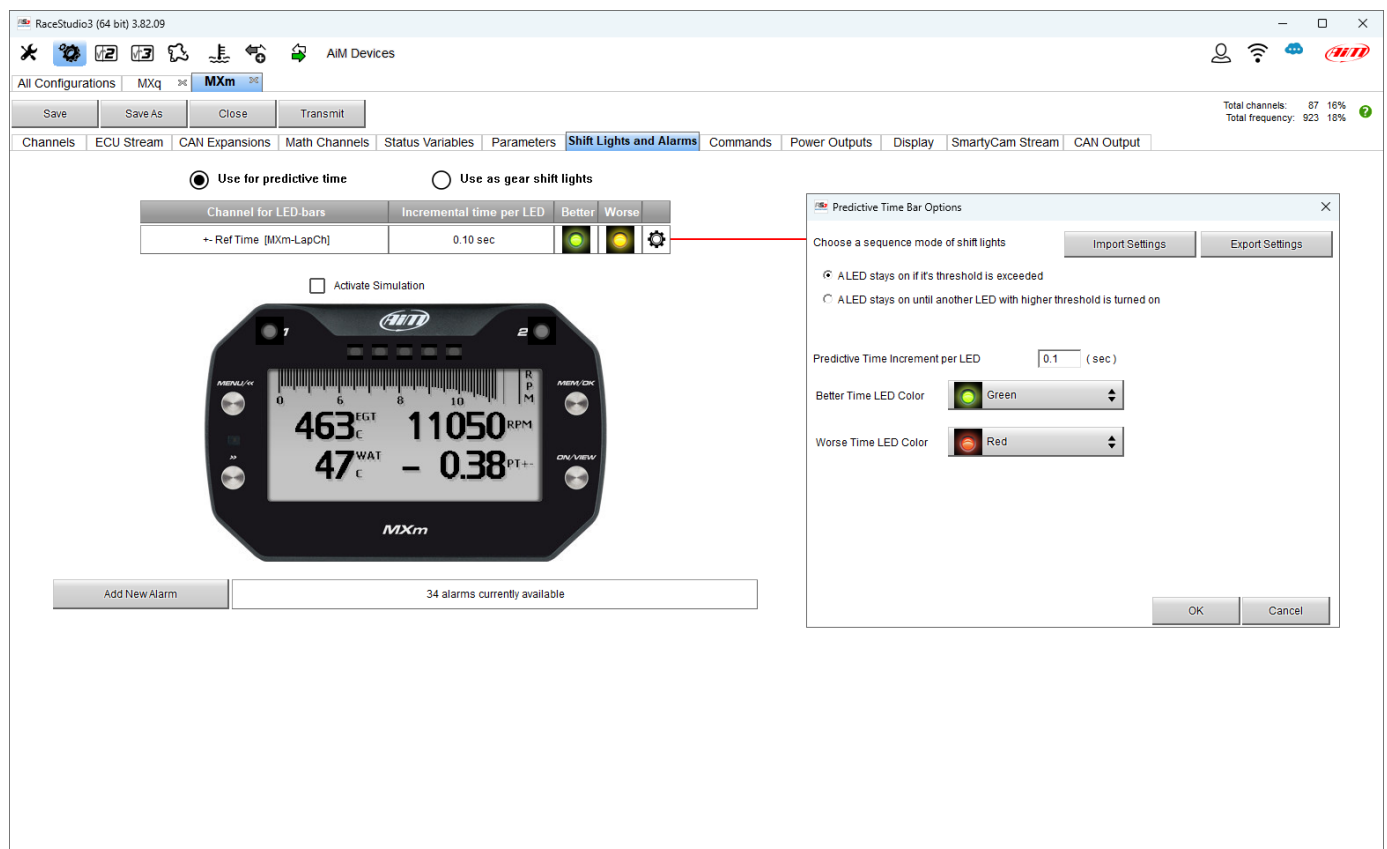

The screenshot shows the RaceStudio3 interface with the 'Shift Lights and Alarms' tab selected. A table at the top shows the configuration for LED bars:

Channel for LED-bars	Incremental time per LED	Better	Worse
~ Ref Time [MXm-LapCh]	0.10 sec		

Below the table is a digital display showing various metrics: 463 EGT, 11050 RPM, 47 WAT, and -0.38 PT. The display also features a bar graph at the top and a gear icon for settings.

To the right, the 'Predictive Time Bar Options' dialog box is open, showing the following settings:

- Use for predictive time** (selected)
- Choose a sequence mode of shift lights:**
  - A LED stays on if its threshold is exceeded
  - A LED stays on until another LED with higher threshold is turned on
- Predictive Time Increment per LED:** 0.1 (sec)
- Better Time LED Color:** Green
- Worse Time LED Color:** Red

At the bottom of the interface, there is a button 'Add New Alarm' and a status bar indicating '34 alarms currently available'.

## Create and set alarms

As for any AiM logger you can import/export alarms using the related buttons but you can also create new ones. To create a new alarm press "+ Add new Alarm"

The screenshot shows the RaceStudio3 interface with the 'Add New Alarm' dialog box open. The dialog is titled 'Alarm Settings' and contains the following fields and options:

- Name:** An empty text input field.
- Log values:** A checkbox that is currently unchecked.
- Sampling Frequency:** A dropdown menu set to '10 Hz'.
- Same condition for activation and deactivation:** A dropdown menu set to 'Same condition for activation and deactivation'.
- Set status to ON:** A dropdown menu set to 'ON' when the following condition is 'verified' for at least '0' seconds.
- Set status to OFF:** A dropdown menu set to 'OFF' when the following condition is 'not verified' for at least '0' seconds.
- Condition:** A dropdown menu set to 'Always FALSE' with an 'Add' button next to it.
- when active execute the following action(s):** A section titled 'Alarm actions in MXm' containing a 'Popup Message timed' action set to 'insert message text' for '5 sec'.
- Alarm ends when:** A dropdown menu set to 'condition no longer met'.
- Save/Cancel buttons:** Located at the bottom right of the dialog.

A red error message at the bottom of the dialog reads: "Name field cannot be empty."

To set the new alarm:

- fill in Alarm name on top of the panel that is prompted
- set activation/deactivation condition (1)
- select the condition pressing the setting button in the related box (2)
- "Condition" panel is prompted: enable the custom condition (3)
- "Select Channel" panel is prompted (4)
- as you can see in the image below, setting a status variable (Water Temp Alarm in the example) you find it in the available channels list: select the channel you prefer and press "OK (5)"
- decide which actions to set among (6):
  - Pop up message timed: fill in the message to be shown on the device display
  - LED: select the LED to switch on and its blinking frequency; you will be asked to set the LED colour
- decide until when keeping on the alarm (7) among:
  - condition no longer met
  - the device is turned off
  - a button is pushed
  - data downloaded
- press "Save" ("8").

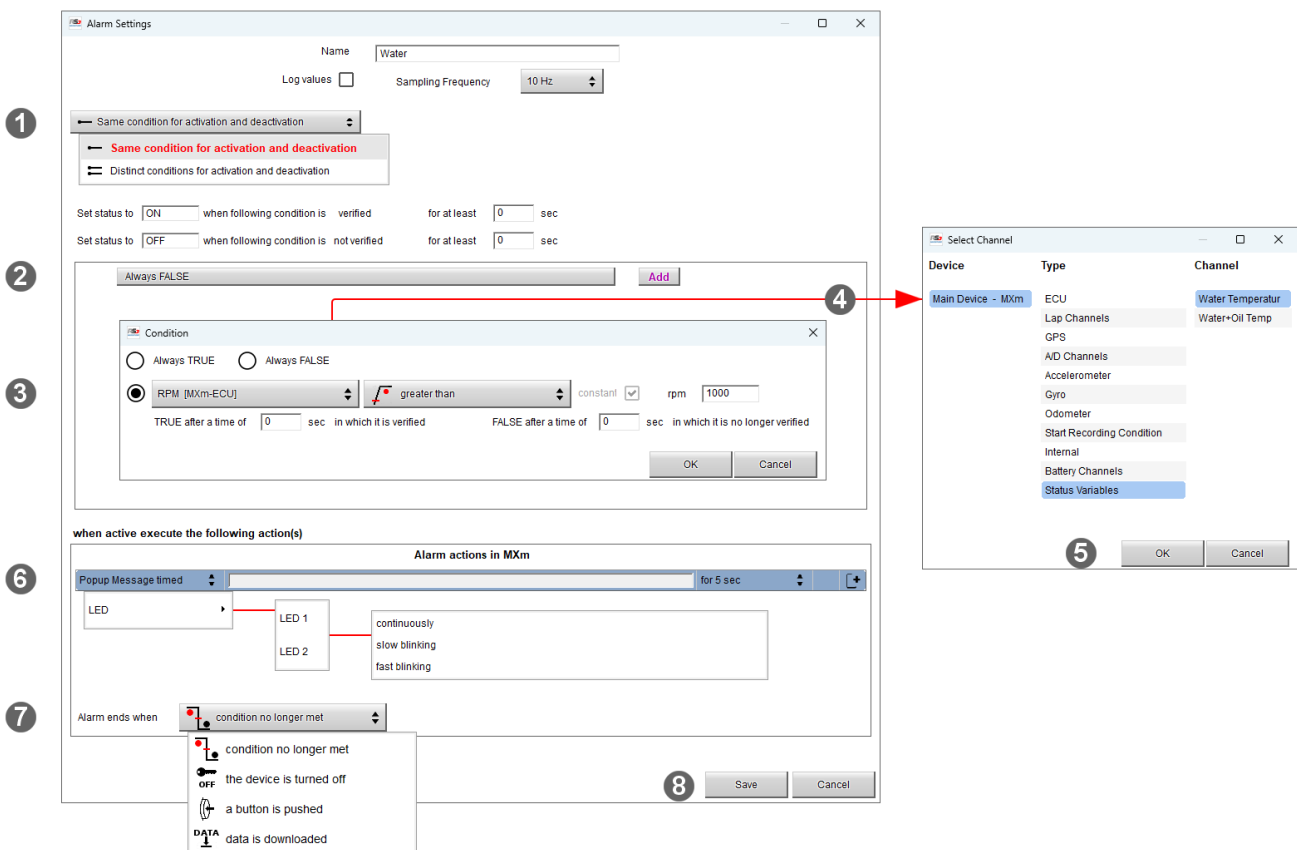



Bottom of the page an Alarm summary is shown. Right clicking on the setting icon, you can edit and modify or delete the alarm.

Use for predictive time  Use as gear shift lights

Channel for LED-bars	Incremental time per LED	Better	Worse
← Ref Time [MXm-LapCh]	0.10 sec		

Activate Simulation

463<sup>EGT</sup><sub>C</sub> 11050<sup>RPM</sup>  
47<sup>WAT</sup><sub>C</sub> - 0.38<sup>PT</sup><sub>+</sub>

Add New Alarm 32 alarms currently available

Event	Alarm
<input checked="" type="checkbox"/> Water	LED: 1
<input checked="" type="checkbox"/> Oil	Popup Message: Oil T

[Edit Selected Alarm](#)  
[Delete Selected Alarm](#)

## 6.2.8 – Commands

MXm and MXq can manage commands that makes the logger execute a precise action. The action it can perform are:

- display a page
- simulate a button pressure

Configuration mode works exactly as Status variable and Shift lights and Alarms.

The screenshot displays the RaceStudio3 (64 bit) 3.82.09 interface. The 'Command Settings' dialog is open, showing the configuration for a command. The 'Action to execute in MXm' dropdown is set to 'Next Display Page'. The condition is set to 'Always FALSE' with 'RPM [MXm-ECU]' greater than '1000 rpm'. The dialog also includes fields for 'TRUE after a time of 0 sec' and 'FALSE after a time of 0 sec'. On the right side of the main window, there are two lists of actions: one in a red box containing 'Next Display Page', 'Previous Display Page', 'First Camera Input', 'Second Camera Input', and 'Goto Page Number'; and one in a blue box containing 'Push button 1', 'Push button 2', 'Push button 3', and 'Push button 4'. The main window also shows 'Total channels: 89 17%' and 'Total frequency: 943 18%' in the top right corner.

### 6.2.9 – Power Outputs setting (MXm only – expert users only)

MXm features 2 Power outputs, that can drain up to 15 Amp each. The power output connector, highlighted here below, is a four pin connector.

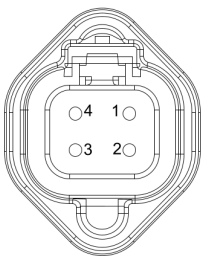
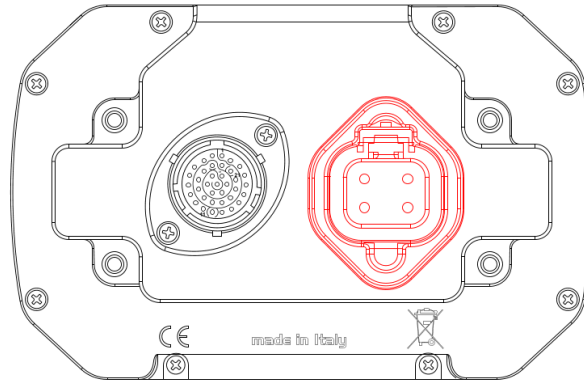

Pin	Function
1	High side output2
2	9-15V power input
3	9-15V power input
4	High side Output1

Each Power output is managed by three channels:

- the output (ON or OFF)
- the drained current
- the Status (OK, Shortcut, Overcurrent, Open Circuit)



To set the two power outputs:

- enter Power output page
- click the power output you want to set or any point of the right part of the view

The screenshot shows the RaceStudio3 (64 bit) 3.82.09 interface. The 'Power Outputs' tab is active, displaying configuration options for 'Out1'. The 'Available Channels List' on the left shows two channels: 'Out1' and 'Out2', both with a maximum load of 15.0 A. The configuration for 'Out1' includes a name field, a 'Log values' checkbox, and a 'Sampling Frequency' dropdown set to 10 Hz. The output type is set to 'Continuous'. The 'Maximum Value of Requested Load (up to 15.0 A)' is set to 15 A. Other parameters include 'Over Current Latch-Off Time' (0.5 sec), 'Number of Retries' (1), 'Retry Delay' (0.5 sec), and 'Minimum Current' (0 A). There are also options for 'Soft Start' and 'Soft Stop' with time settings. A dropdown menu is set to 'Same condition for activation and deactivation'. The bottom section contains text indicating activation and deactivation conditions.

Power Output	Description	Pin	Max Load
<input checked="" type="checkbox"/>	1 Out1		15.0 A
<input type="checkbox"/>	2 Out2		15.0 A

Name: Out1 Log values  Sampling Frequency 10 Hz

Inductive Load  Continuous  PWM  Square Wave

Maximum Value of Requested Load (up to 15.0 A) 15 A

Over Current Latch-Off Time 0.5 sec

Number of Retries 1

Retry Delay 0.5 sec

Minimum Current 0 A

Soft Start in a time of 1 sec

Soft Stop in a time of 1 sec

← Same condition for activation and deactivation

It is activated when:  
( Always FALSE)  
is verified

It is deactivated when:  
It is not verified

The setting panel to be filled in is prompted: it is made up of two tabs shown in the following images:

- Settings and
- Related Channels

Both tabs values can be logged enabling "Log values" checkbox.

The screenshot displays the 'Modify Output Signal' dialog box with the 'Settings' tab selected. The 'Name' field is 'Out1', 'Log values' is checked, and 'Sampling Frequency' is '10 Hz'. The 'Maximum Value of Requested Load' is set to 15 A, 'Over Current Latch-Off Time' is 0.5 sec, 'Number of Retries' is 1, 'Retry Delay' is 0.5 sec, and 'Minimum Current' is 0 A. The 'Set status to' section is configured to 'ON' when the condition is verified for at least 0 sec, and 'OFF' when the condition is not verified for at least 0 sec. A condition is added, showing 'Always FALSE' in the list. A red box highlights the 'Always FALSE' entry and the 'Add' button. Below this, a 'Condition' dialog box is shown, where 'RPM [MXm-ECU]' is selected, the condition is 'greater than', and the value is '1000 rpm'. The 'TRUE after a time of' and 'FALSE after a time of' fields are both set to 0 sec. The 'Condition' dialog box has 'OK' and 'Cancel' buttons.



Modify Output Signal

Settings **Related Channels**

Current of Power Output      Name: **Out1Current**      Log Values       Sampling Frequency: 10 Hz

Unit: A      Display Precision: 1 decimal place

Status of Power Output      Name: **Out1Status**      Log Values       Sampling Frequency: 10 Hz

Status Legend

Value	0	1	2	4	8	16	32
Label	ok	sc	open	htemp	ovcur	unvol	ovvol
Description	ok	short circuit	open circuit	high temperature	over current	under voltage	over voltage

OK      Cancel

## 6.2.10 – Display settings

MXm and MXq can have up to eight pages to be set via software. Each page can have from 1 to 8 fields and can be set as you prefer.

- enter "Display" tab
- a panel shows up where you can select the display page you prefer
- select the page and press "OK"
- repeat the operation for the number of pages you want to set

The screenshot shows the RaceStudio3 (64 bit) 3.82.09 interface. The 'Display' tab is active, and a 'Select a page to add' dialog box is open. The dialog displays 16 different data field templates (P1 to P16). A red box highlights the 'Bargraph 2' template, which features a gauge with a needle and numerical values for RPM (20500) and OILP (4.2 bar). The main interface shows the 'Display' tab selected, and a 'Channel' dropdown menu is visible, currently set to 'Not Set'.



When the page has been selected two setting panels appears bottom of the page:

- on the left a panel that shows as many rows as the fields to be set
- on the right a panel that shows the channels group you can set in that field and all the channels in it included; you can drag and drop the channel you want to set in the desired field or double click on it
- if you added more display pages the one you are setting is indicated top of the tab as highlighted here below; repeat the operation for all the pages loaded in the configuration.

The screenshot shows the RaceStudio3 (64 bit) 3.82.09 interface. The top menu bar includes 'Channels', 'ECU Stream', 'CAN Expansions', 'Math Channels', 'Status Variables', 'Parameters', 'Shift Lights and Alarms', 'Commands', 'Display', 'SmartyCam Stream', and 'CAN Output'. The 'Display' tab is active, showing two pages: 'Page 1' and 'Page 2'. 'Page 1' is highlighted with a red box. Below the pages, there are two configuration panels. The left panel is titled 'INFO LINE' and contains a table with columns for 'Device', 'Type', and 'Channel'. The right panel is a list of channels with columns for 'Device', 'Type', and 'Channel'. The 'Device' column is currently set to 'Main Device - MXq' and 'NOT SET -'. The 'Type' column lists various sensors and systems like 'ECU', 'Lap Channels', 'GPS', 'Accelerometer', 'Gyro', 'Odometer', 'Internal', 'Battery Channels', and 'Status Variables'. The 'Channel' column lists specific data points like 'RPM', 'SpeedVeh', 'Spd', 'SpFL', 'SpFR', 'SpRL', 'SpRR', 'Gear', 'WaterTemp', 'ECT', 'TurboBoost', 'TurB', 'TCSBrakeEvent', 'TCSB', 'TCSEngEvent', 'TCSE', 'StabChrtFtalt', 'SCTE', 'StabChrtMTXT', 'SCMT', 'TyreRvMile', 'TjRM', 'FuelLevelMean', 'Fuel', 'FuelInst1', 'INS1', and 'FuelInst2', 'INS2'.

Device	Type	Channel
Main Device - MXq	ECU	RPM
-- NOT SET --	Lap Channels	SpeedVeh
	GPS	SpeedFL
	Accelerometer	SpeedFR
	Gyro	SpeedRL
	Odometer	SpeedRR
	Internal	Gear
	Battery Channels	WaterTemp
	Status Variables	ECT
		TurboBoost
		TurB
		TCSBrakeEvent
		TCSB
		TCSEngEvent
		TCSE
		StabChrtFtalt
		SCTE
		StabChrtMTXT
		SCMT
		TyreRvMile
		TjRM
		FuelLevelMean
		Fuel
		FuelInst1
		INS1
		FuelInst2
		INS2

## 6.2.11 – SmartyCam stream setting

MXm/MXq can be connected to AiM SmartyCam 2 and SmartyCam3 (both Standard and Advanced) using the CAN bus to show the data you wish on SmartyCam video.

**SmartyCam 2 and SmartyCam 3 Default** configuration procedure is as follows:

- click on the channel to set and a setting panel is prompted
- it shows all channels and/or sensors that fits the selected function
- in case you do not find the channel or the sensor in the list enable “Enable all channels for functions” checkbox and all channels/sensors will be shown

The screenshot shows the RaceStudio3 interface with the 'SmartyCam Stream' configuration window. The 'SmartyCam 3' radio button is selected. Below it, there is a checkbox for 'Enable all channels for functions' which is checked. A table lists the following functions and channels:

ID	SmartyCam Function	Channel
CC01	Engine RPM	RPM [MXq-ECU]
CC02	Speed	GPS Speed [MXq-GPS]
CC03	Gear	Gear [MXq-ECU]
CC04	Water Temp	WaterTemp [MXq-ECU]
CC05	Head Temp	--- Not Set ---
CC06	Exhaust Temp	--- Not Set ---
CC07	Oil Temp	--- Not Set ---
CC08	Oil Press	--- Not Set ---
CC09	Brake Press	--- Not Set ---
CC10	Throttle Pos	--- Not Set ---
CC11	Brake Pos	--- Not Set ---
CC12	Clutch Pos	--- Not Set ---
CC13	Steering Pos	SWAngle [MXq-ECU]
CC14	Lambda	0LC1S Lambda [Exp: 0LC1S-AC]
CC15	Lateral Accel	LateralAcc [MXq-Accel]
CC16	Inline Accel	InlineAcc [MXq-Accel]
CC17	Fuel Level	--- Not Set ---
CC18	Battery Voltage	Ext Battery [MXq-Batt]
CC19	Vertical Accel	VerticalAcc [MXq-Accel]

The 'Select Channel' dialog box is open, showing a list of channels. The 'FuelLevelMean' channel is selected. The dialog box also shows the device 'Main Device - MXq' and the type 'ECU'.



Once the channel selected and set in the configuration it is shown in the software view.

The screenshot shows the RaceStudio3 (64 bit) 3.82.09 interface. The 'SmartyCam Stream' window is open, displaying a list of channels for configuration. The 'Fuel Level' channel (CC17) is highlighted with a red box.

Enable all channels for functions

ID	SmartyCam Function	Channel
CC01	Engine RPM	RPM [MXq-ECU]
CC02	Speed	GPS Speed [MXq-GPS]
CC03	Gear	Gear [MXq-ECU]
CC04	Water Temp	WaterTemp [MXq-ECU]
CC05	Head Temp	--- Not Set ---
CC06	Exhaust Temp	--- Not Set ---
CC07	Oil Temp	--- Not Set ---
CC08	Oil Press	--- Not Set ---
CC09	Brake Press	--- Not Set ---
CC10	Throttle Pos	--- Not Set ---
CC11	Brake Pos	--- Not Set ---
CC12	Clutch Pos	--- Not Set ---
CC13	Steering Pos	SWAngle [MXq-ECU]
CC14	Lambda	OLC1S Lambda [Exp. OLC1S-AC]
CC15	Lateral Accel	LateralAcc [MXq-Accel]
CC16	Inline Accel	InlineAcc [MXq-Accel]
CC17	Fuel Level	FuelLevelMean [MXq-ECU]
CC18	Battery Voltage	Ext Battery [MXq-Batt]
CC19	Vertical Accel	VerticalAcc [MXq-Accel]

To transmit a different set of information **SmartyCam Advanced** configuration procedure is needed. **Please note: this function is for expert users only.** The procedure is:

- select “SmartyCam 3 Advanced option
- press “Add new payload”
- create your stream configuring all fields of “Set CAN Header Details” panel that is prompted
- press “OK”
- name the protocol

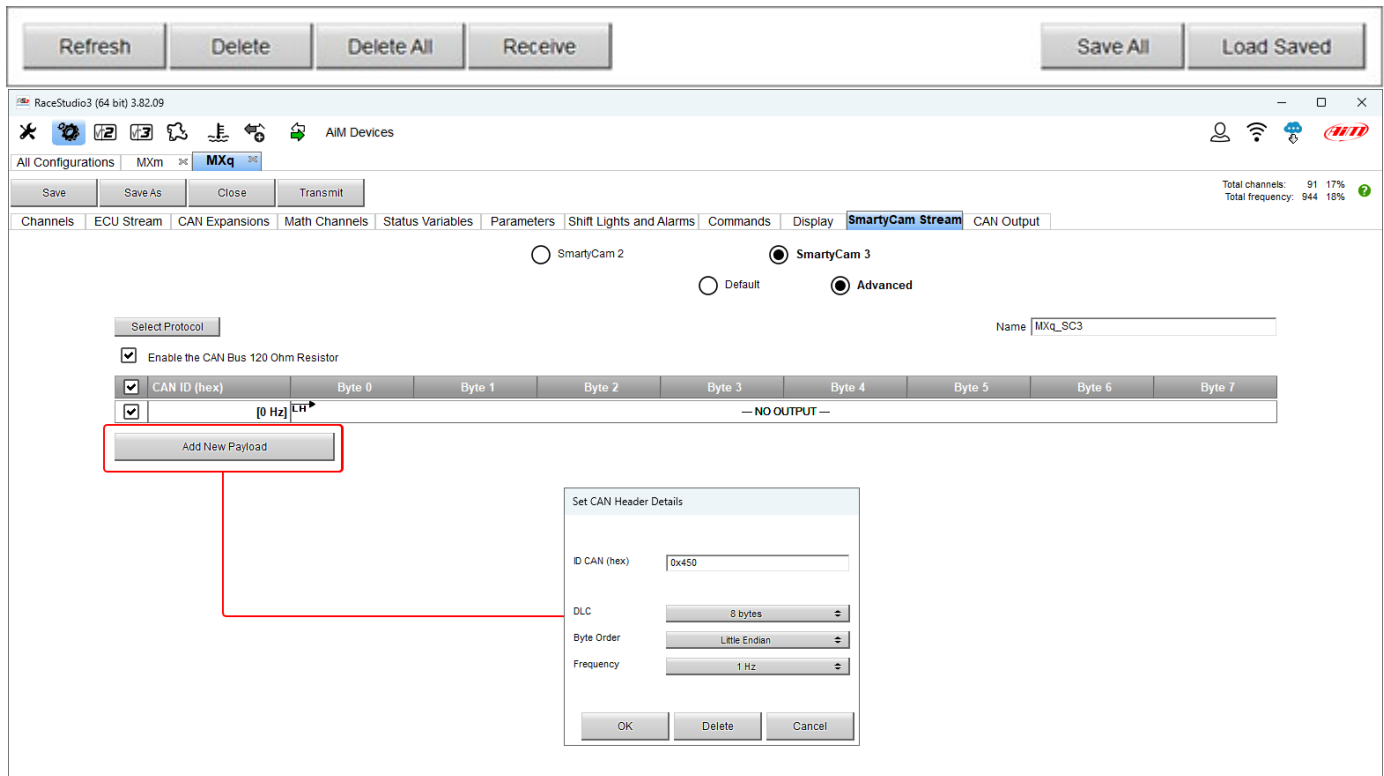

## 6.2.12 – CAN Output

This tab is used to transmit a CAN stream including channels required by AiM CAN bus and works exactly as SmartyCam 3 Advanced stream so is **for expert users only**.

## 6.3 – Managing a track with RaceStudio 3

Track Manager function of RaceStudio 3 manages the tracks of the connected device. Press “Tracks” icon.

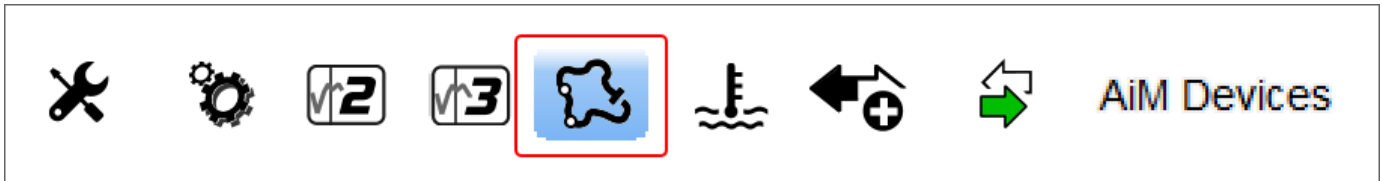

The main page is divided in three columns; **left:**

- on top, the filters that allow to collect many tracks following customized criteria; by default, all tracks are shown
- bottom left, the connected devices (in the image, “MXq ID 1620415”)

**Middle:**

- top left a fast search bar where to type the word(s) to search (you can decide whether searching all the words or not)
- top right “i” icon shows research criteria:
  - track long name is the name you see in bold in each track box
  - track short name is the track name shown on the display of the logger and is the name you find top right of each track box
  - track city is the name of the city the track is located in
- right of any track a setting icon allows to open (edit) the track, export the track, transmit the track to the connected item
- all the tracks stored in RaceStudio 3 database. It automatically updates when a connection to the Internet is available.

**Right:**

- the datasheet of the track you are mousing over.

As said before the connected device is shown left bottom of the page. To load tracks on it select these you want to load in the central column and press "Transmit" In case you created tracks they are labelled "user".

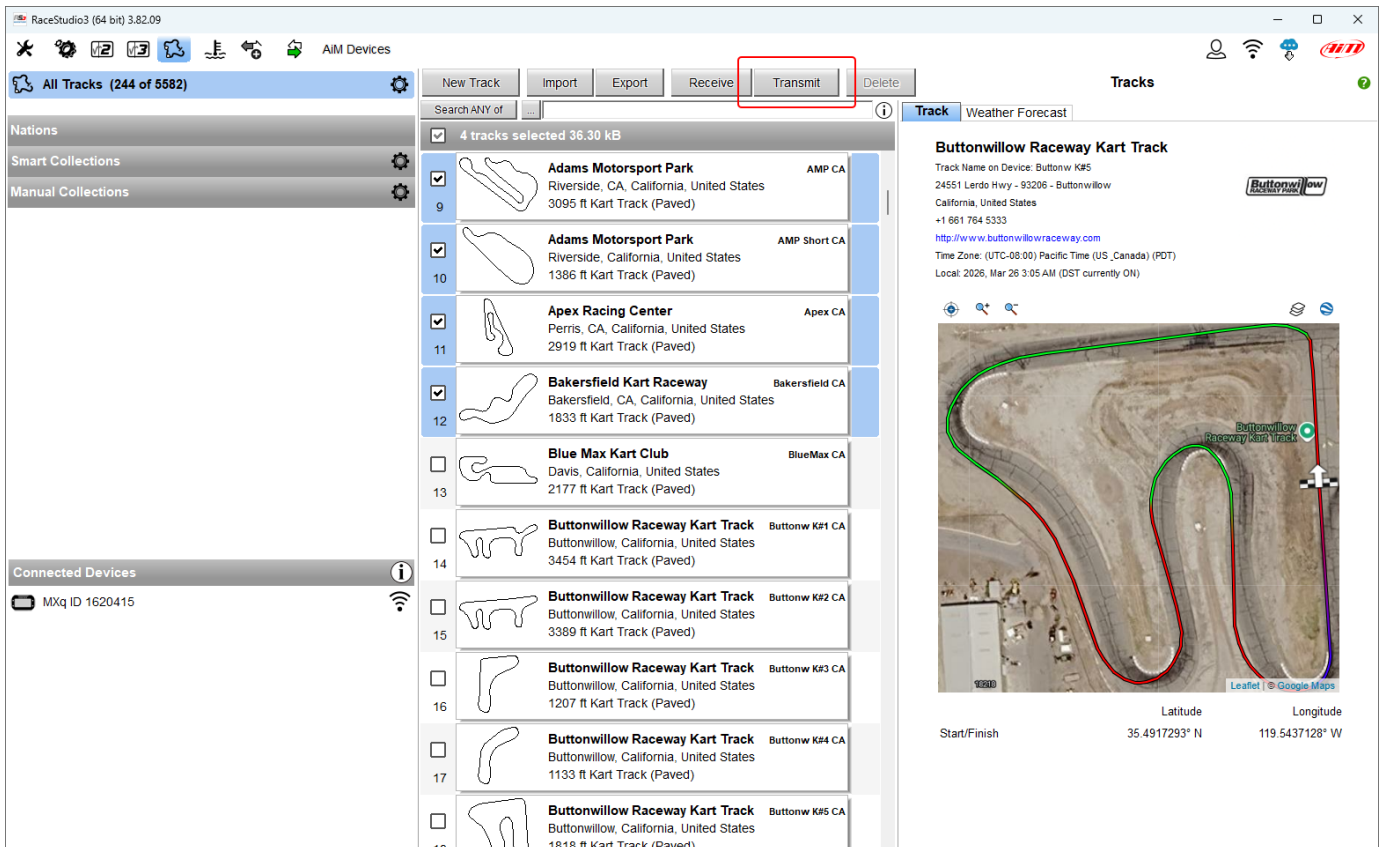

The page central keyboard allows to:

- **New:** create a new "custom" track
- **Import/Export:** import/export one or more tracks in/from your device
- **Receive:** receive from the connected device the tracks you created
- **Transmit:** transmit one or more tracks from the PC to the connected device
- **Delete:** delete one or more tracks from RaceStudio 3 Database





To edit and modify a track select "Open Selected Track(s) in track database view as shown below and the dedicated panel is prompted. Here you can:

- modify track displayed name
- modify start/finish line
- add/remove splits

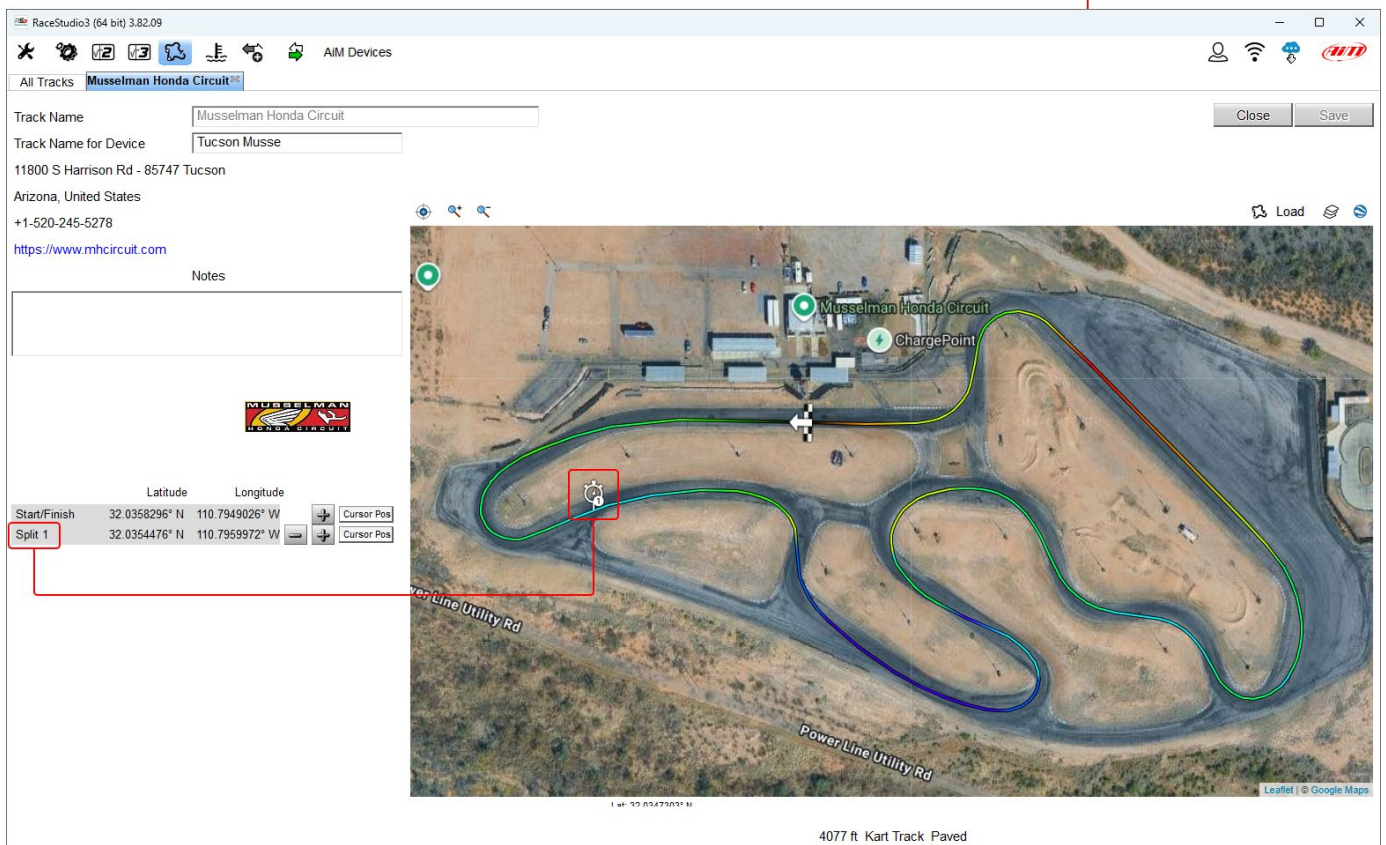
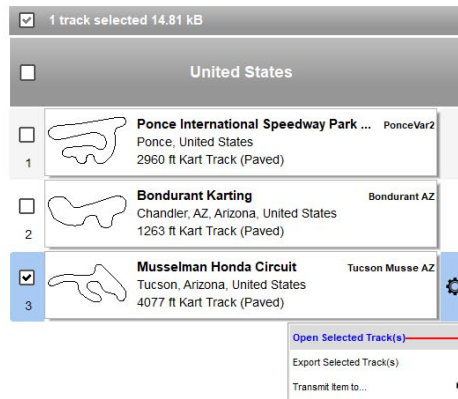



To see and manage the tracks stored in the connected device click on it bottom left of the software view and the dedicated view, shown below, is prompted. Search criteria and working mode are shown below.

The screenshot shows the 'Tracks' view in RaceStudio3. The window title is 'RaceStudio3 (64 bit) 3.82.09'. The main menu includes 'Live Measures', 'Data Download', 'WiFi and Properties', 'Settings', 'Tracks', 'Predictive Reference Lap', 'Counters', 'Logo', and 'Firmware'. Below the menu are buttons for 'Refresh', 'Delete', 'Delete All', 'Receive', 'Save All', and 'Load Saved'. A search bar is labeled 'Search ANY of' and has a dropdown arrow. A tooltip explains the search criteria: 'Words entered in the search box are matched against: - track long name contains ... - track short name contains ... - track city begins with ...'. The track list is as follows:

Track ID	Track Name	Location	Track Type	Short Name
1	Ten Mile Speedway	Pitkin, Louisiana, United States	1/10 mi Oval (Dirt)	
2	105 Speedway	Cleveland, Texas, United States	1/4 mi Oval (Dirt)	105S TX
3	201 Go-Kart Speedway	New Boston, Texas, United States	1/9 mi Oval (Paved)	201GoKart TX
4	Aeroclub 25 de Mayo	25 De Mayo, Buenos Aires, Argentina	2544 ft Off Road (Dirt)	25 De Mayo
5	Aeroclub 25 De Mayo	25 De Mayo, Buenos Aires, Argentina	2773 ft Off Road (Dirt)	25 De Mayo 2
6	281 speedway	Stephenville, Texas, United States	3/10 mi Oval (Dirt)	281 TX
7	304 Speedway - Brushcreek Falls RV Resort	Princeton, West Virginia, United States	1/8 mi Oval (Dirt)	304 Speedway WV
8	411 Motor Speedway	Seymour, Tennessee, United States	1/4 mi Oval (Dirt)	411 Seymour TN
n	4-17 Southern Speedway	Punta Gorda, Florida, United States	3/10 mi Oval (Paved)	417SS FL

Use the top keyboard buttons to:

- **Refresh:** after having loaded new tracks on the connected device you can refresh the list of the tracks in it stored
- **Delete/Delete all:** delete some or all tracks stored in the connected device
- **Receive:** receive and store in the PC database tracks stored in the connected device
- **Save All/Load saved:** save all tracks/load on the PC the tracks saved in the logger

Refresh    Delete    Delete All    Receive    Save All    Load Saved

## 6.4 – ECU Driver builder (expert users only)



If your vehicle ECU is not included in RaceStudio 3 software you can use CAN Driver builder to create your own CAN protocol. Press CAN Protocols button shown here above and then "New". The panel shown below is prompted. You can add a new ECU Manufacturer and/or a new ECU model.

**Please note: this RaceStudio 3 function is for expert users only** and a CAN Driver builder user manual can be freely downloaded from AiM website at [www.aim-sportline.com](http://www.aim-sportline.com), documentation area software/firmware section.

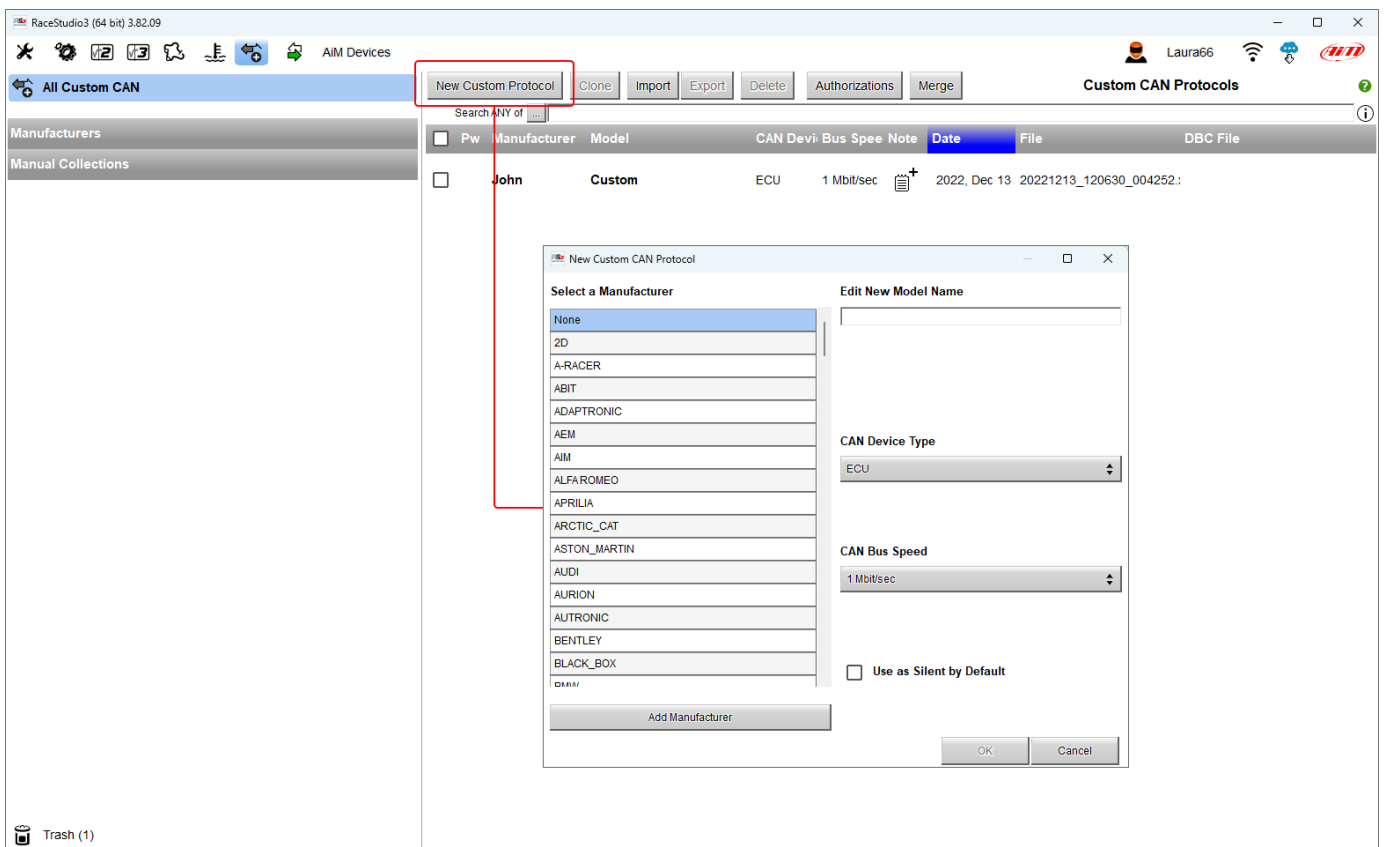

## 6.5 – The device window

Clicking on the connected device bottom left of the view “Online” view is prompted. CAMBIARE IMMAGINE

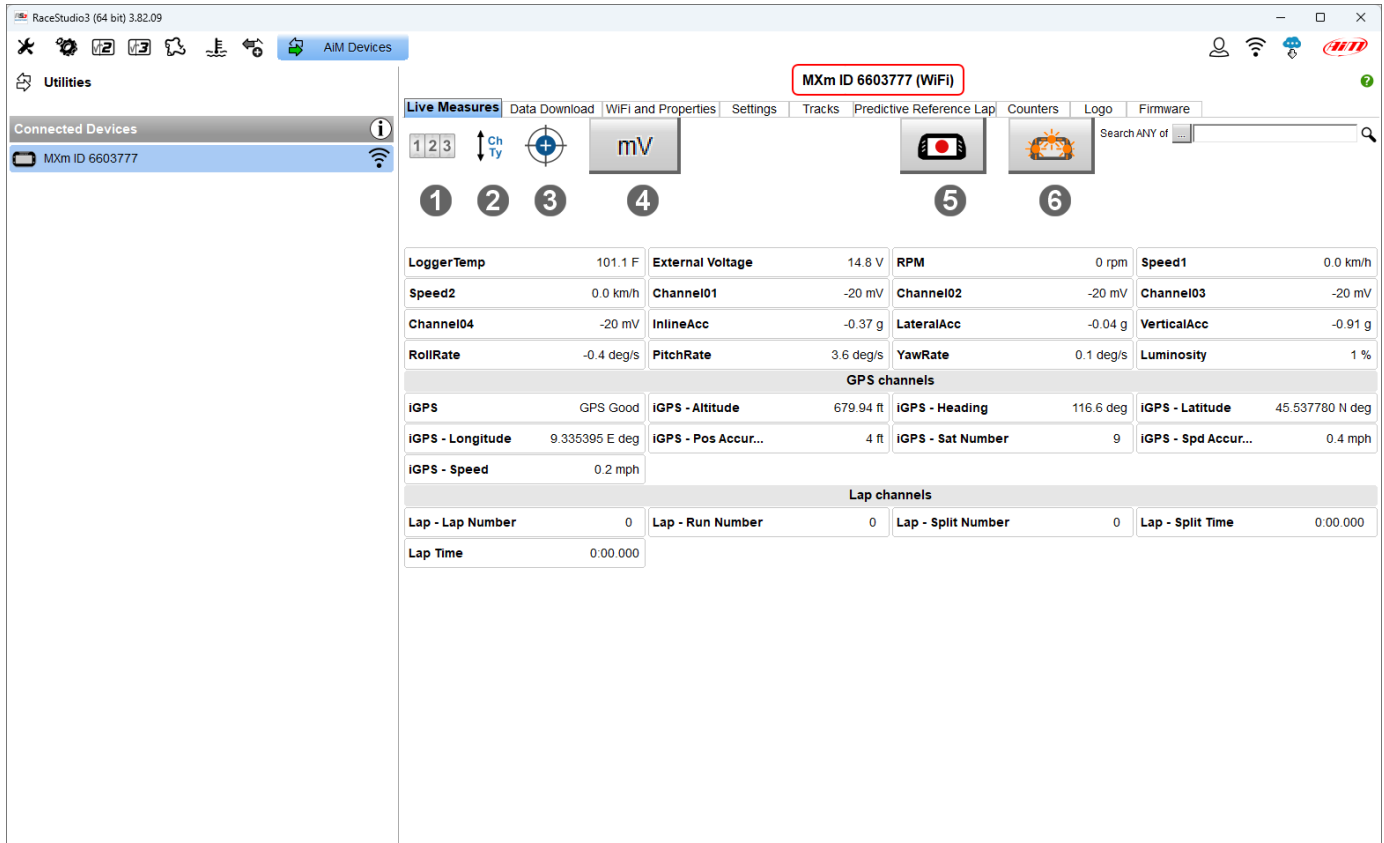

The screenshot shows the RaceStudio3 (64 bit) 3.82.09 application window. The 'Live Measures' tab is active, displaying real-time data for a connected MXm device (ID 6603777). The interface includes a top navigation bar with tabs: Live Measures, Data Download, WiFi and Properties, Settings, Tracks, Predictive Reference Lap, Counters, Logo, and Firmware. A central control area features six numbered buttons (1-6) for various functions. Below this is a data table with columns for various sensors and their current values.

LoggerTemp	101.1 F	External Voltage	14.8 V	RPM	0 rpm	Speed1	0.0 km/h
Speed2	0.0 km/h	Channel01	-20 mV	Channel02	-20 mV	Channel03	-20 mV
Channel04	-20 mV	InlineAcc	-0.37 g	LateralAcc	-0.04 g	VerticalAcc	-0.91 g
RollRate	-0.4 deg/s	PitchRate	3.6 deg/s	YawRate	0.1 deg/s	Luminosity	1 %
<b>GPS channels</b>							
IGPS	GPS Good	IGPS - Altitude	679.94 ft	IGPS - Heading	116.6 deg	IGPS - Latitude	45.537780 N deg
IGPS - Longitude	9.335395 E deg	IGPS - Pos Accur...	4 ft	IGPS - Sat Number	9	IGPS - Spd Accur...	0.4 mph
IGPS - Speed	0.2 mph						
<b>Lap channels</b>							
Lap - Lap Number	0	Lap - Run Number	0	Lap - Split Number	0	Lap - Split Time	0.00.000
Lap Time	0.00.000						

The page is made up of 9 tabs.

“**Live Measures**” tab shows the logger actual values and features six buttons on top that allows to:

- Start/stop live measure stream from MXm (1)
- Show channels as managed by the firmware (Sort by configuration), in alphabetical order or by channel type (2)
- Calibrate/auto-calibrate channels that need it (3)
- Show values in millivolt  $\mu\text{V}$  (4)
- Start/stop data recording (5)
- Make MXm LEDs blinking (6); this is the quickest and easiest way to test PC-device connection

**Data Download** tab is to download sampled data, see the related chapter

**Wi-Fi and Properties** layer is to manage Wi-Fi configuration – see the related paragraph.

**Settings** tab allows to set different parameters:

**Date and Time** to set:

- Date and time format
- Time/Date synchronization; available options are:
  - By GPS track
  - Manual
  - PC synchronization

**Display** to set:

- display backlight colour
- Night vision (ON/AUTO/OFF)

**Predictive Time:**

- Channel recording: ON/OFF
- Reference Lap; available options are:
  - Best lap of Test
  - Best lap of today
  - Previous lap
- User reference lap

The arrows left of the buttons are to scroll the option while the right ones open the menus.

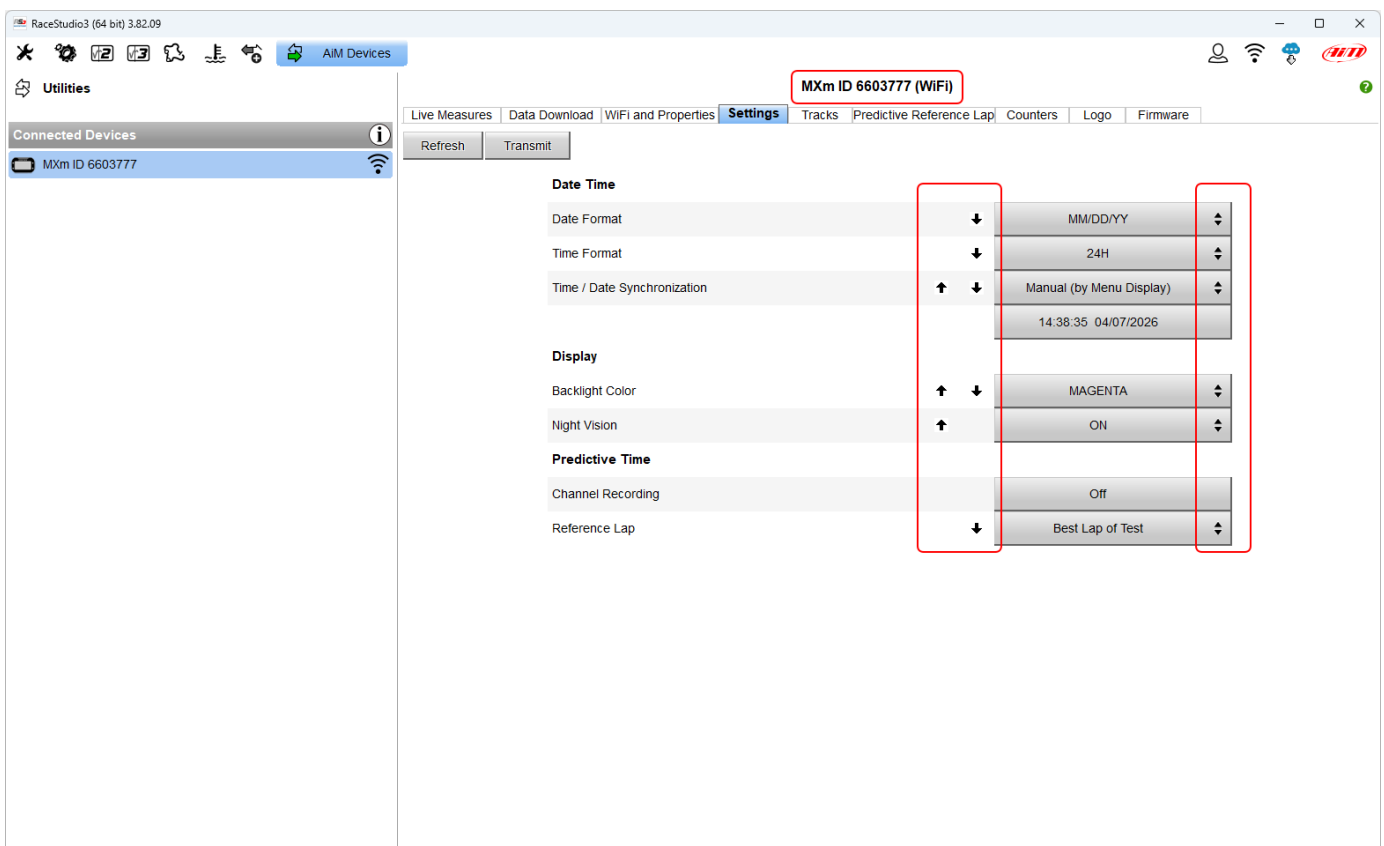

**Tracks** layer manages the tracks stored in the logger memory.

## Predictive Reference Lap

MXm and MXq can compute and show the predictive lap time stored in their memory or an user-generated reference lap. As shown here below this view features three useful keyboard:

- top left and top right of the view the keyboards that manage the file properties
- central is the keyboard to move reference file(s) from/to PC/device

The view has two columns:

- on the left the reference lap(s) file(s) stored in the PC
- on the right the reference lap(s) file(s) stored in the logger

At the very first time both columns of the view are empty except if a firmware generated file has been stored in the system. The firmware automatically generates reference files like the best of the test and the best lap of today as well ad previous lap and they can be uploaded to the software using the keyboard. CAMBIARE IMMAGINE

The screenshot shows the 'Predictive Reference Lap' view in RaceStudio3. The main area is divided into two columns: 'Files On PC, sorted by Track Name, then Date/Time' and 'Files On Device, sorted by Track Name, then Date/Time'. A central toolbar contains several icons for file management. Red boxes and arrows highlight specific UI elements and their functions:

- MXm ID 6603777 (WiFi)**: A red box highlights the device name in the top right corner.
- File Management Keyboards**: Two keyboards at the top left and top right manage file properties.
- Central Keyboard**: A central keyboard manages reference file(s) from/to PC/device.
- File Lists**: Two tables show file lists for PC and Device. The PC table has columns: Track Name, Date/Time, Lap Time, File Name, Co... The Device table has columns: Track Name, Date/Time, Lap Time, File Name, Co... A note in the Device table states: 'This track configuration features no predictive lap information. Please refer to documentation to learn more about this feature.'
- Toolbar Icons and Functions**:
  - Click to copy to your device all the selected files from PC
  - Click to copy on PC all the selected files from your device
  - Click to save all predictive reference laps from device to a file
  - Click to load all predictive reference laps from a file to your device
  - Click for tx/rx operations with your device
  - Click to change file name or comment...
  - Click to delete selected file(s)
  - Click to import file(s) from disk
  - Click to export selected file(s) to disk
  - Click to make selected file the default choice for track



**Counters** allows to set/reset each odometer except system one that is not editable. Setting icon top of counters table allows to switch from decimal to Imperial measure units as well as to decide the number of decimal places to show on the display

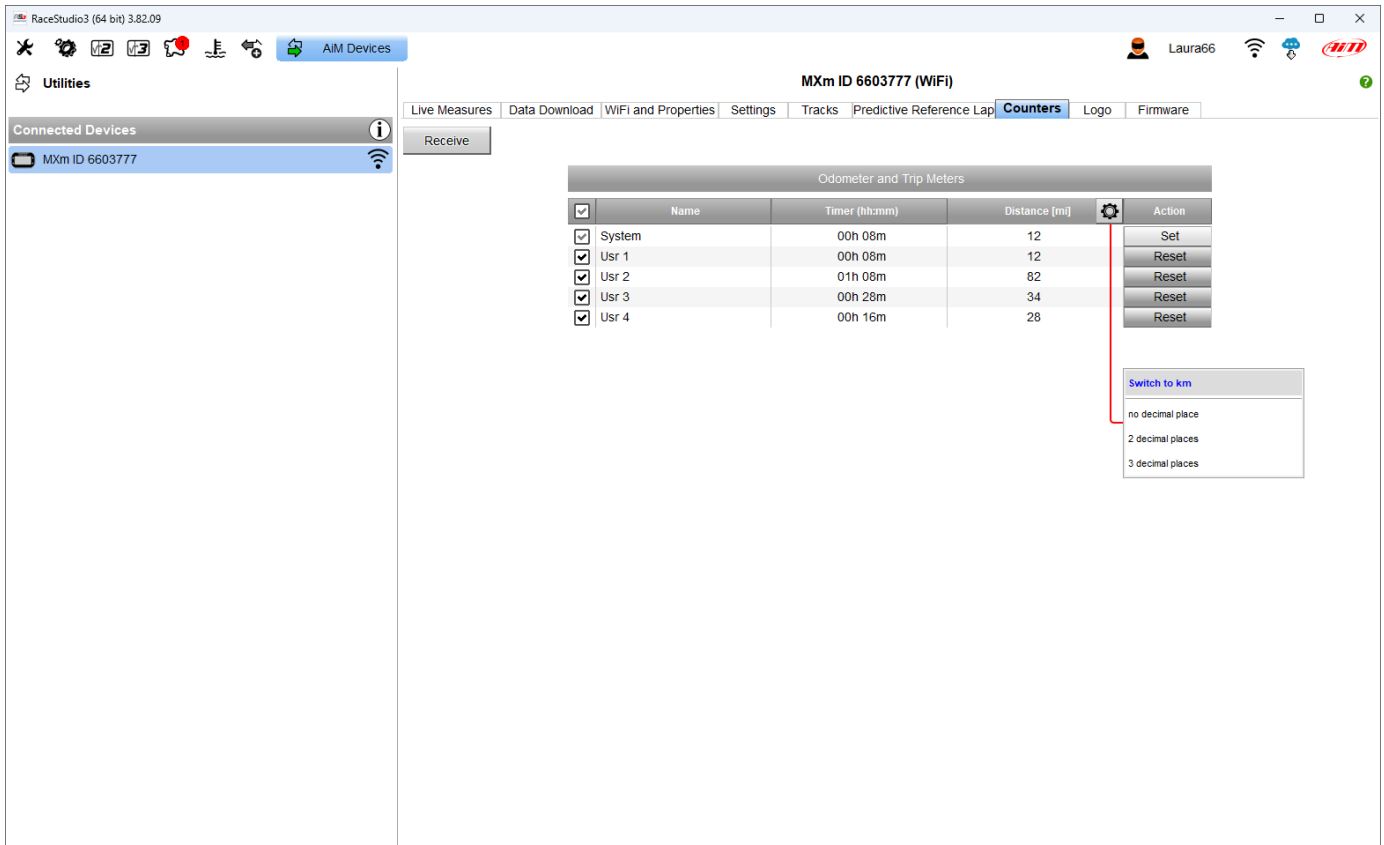

**Logo** allows to transmit/receive the logo that shows up when switching the logger on; supported image formats are JPEG or BMP; always use the most recent Windows™ versions-whose graphic libraries are more updated.

### Firmware layer

- shows hardware, firmware and booter version of your logger
- shows the same information concerning the connected expansions
- allows to check if more recent versions of firmware are available using "Firmware updates" buttons right of the layer.

## 7 – On the track

Some pages are available for online visualization. To scroll them press “NEXT”. Pages can change according to the device configuration.

### 7.1 – Track page

This is the first page that appears when you switch the logger on and can be recalled pressing “TRACK” button Starting the engine of the car it goes away automatically. It shows:

- on the left, if you are in a 10km distance from the selected track, the track; you can select a new one manually or automatically (“MENU/Track Management”); in case of “Automatic” selection the track is selected according to the position of your vehicle; if the track you are running on is not included in the logger database the logger switches to “learning mode” as shown in the bottom image here on the right
- on the right the satellite bar (visible satellites and signal level of each one).

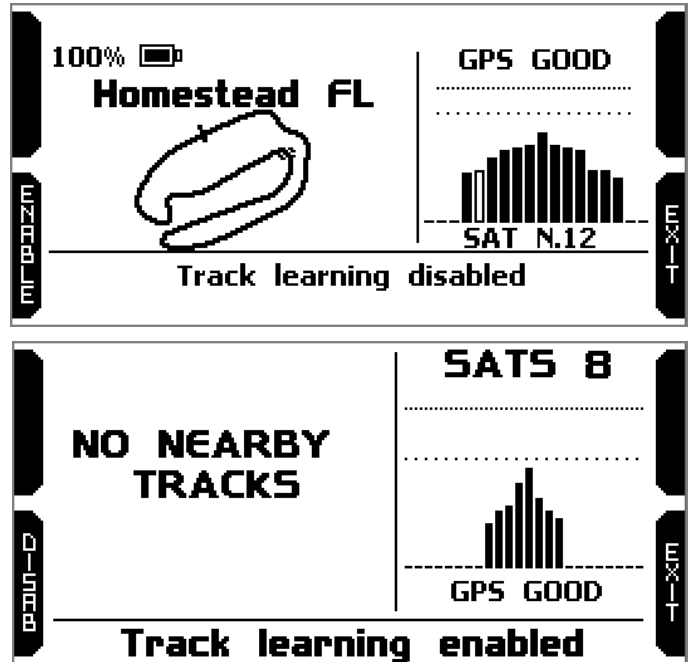

### 7.2 – Other pages

At very first switch on, when you quit track page the logger shows Laptime Page; afterwards it will show the last page you displayed.



## 8 – Data recall

At the end of the test you can recall sampled data pressing “MEM/OK”.

First page shown is a summary page  
Select the session you want to see and press “ENTER”

TEST SESSIONS	
TODAY: Albany GA	
07/06/2020: Albany GA	
02/06/2020: Albany-5a NY	
15/10/2020: Avenger AL	
05/10/2020: Auburndal	

Once the session selected you enter session summary page where all tests in a box showing time of the test and best lap of the test.  
Select the test you want to see and press “ENTER”.

17/09/2020: Albany GA		
10:09 10 Laps B 2:23.56	12:26 18 Laps B 2:23.09	13:46 13 Laps B 2:22.90
14:36 10 Laps B 2:21.96	15:27 12 Laps B 2:22.06	16:06 16 Laps B 2:23.46

In page 1 (the number is top right of the page) you see the three best lap of the test with max speed value of each lap.  
Press “PAGE”.

17/09/2020: 10:09 1			
MAX RPM	MAX SPEED		
---	326		
Lap	Best Laps	RPM	km/h
4	2:23.56	---	131 118
11	2:25.11	---	131 106
8	2:26.16	---	130 96

Page 2 is a histogram test summary. Moving the cursor left and right you can see all laps and the difference versus the best lap of that test.

17/09/2020: 10:09 2	
Best:	2:23.56
Lap 3:	2:25.88      Diff: 02.32

Page 3 shows lap time with speed max/min values.  
Press “PAGE”.

Lap 3 3		
Lap Time	RPM	km/h
2:25.88	---	130 96



Page 4 shows RPM graph of the selected lap.  
Use "PREV" and "NEXT" buttons to see RPM and speed values in all points of the selected lap.

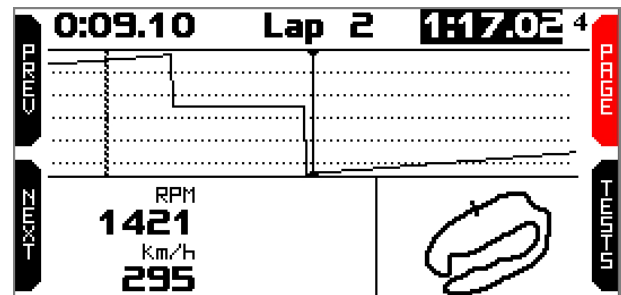

Page 5 shows the laps of the test with lap time, and RPM and Speed min/max values. Use:

- "PAGE" button to come back to page "1"
- "TESTS" buttons to come back to session summary page.

TODAY 12:42				5
Lap	Lap Time	RPM	km/h	
1	0:47.31	15710 7142	260 118	
2	1:17.02 <sub>B</sub>	16375 7	450 100	
3	1:19.22	16372 13	331 100	
4	2:54.54	16379 4	450 1	

## 9 – Data download

Once logger-PC connection is established activate “Download” tab to download sampled data.

The screenshot shows the RaceStudio3 (64 bit) 3.34.01 interface. The main window displays the 'Download' tab for MXm ID 7800102. The interface includes a sidebar with 'All Configurations', 'Devices (2)', 'Manual Collections', and 'Connected Devices' (showing MXm ID 7800102). The main area shows a table of data files with columns for selection, date/time, track name, file name, and size. The 'Download' button is highlighted with a red box.

2 selected 2.7 MBytes	
<input checked="" type="checkbox"/>	ott 25
<input checked="" type="checkbox"/>	ott 31
Homestead FL 3 selected 4.1 MBytes	
<input checked="" type="checkbox"/>	ott 28 12:42
1	Homestead FL ?
	a_0005.xrz 1.93 MB
<input checked="" type="checkbox"/>	ott 28 08:39
2	Homestead FL ?
	a_0004.xrz 28.35 kB
<input checked="" type="checkbox"/>	ott 27 15:02
3	Homestead FL ?
	a_0003.xrz 2.20 MB
<input type="checkbox"/>	ott 18
<input type="checkbox"/>	ott 24

This page shows all information about the files stored in the system: number of laps, best lap, date/time and file dimensions. Select one or more files and press “Download” to download and analyse them.



# 10 – Data Analysis



When data have been downloaded press Analysis icon and Race Studio Analysis software will open showing this page.

The screenshot displays the RaceStudio3 software interface. On the left, a list of events is shown, with the selected event being '2024, November 21' at 'KonaibottO'. The main area shows a detailed view of this race, including a table of lap times and percentages. Below the table is a graph of GPS Speed (mph) vs Distance (mi).

Lap	Time	Pct	Min	Avg	Max
1	1:16.833	123.12	22.0	37.0	63.1
2	1:05.887	105.58	24.4	42.9	74.6
3	1:04.757	103.77	24.9	43.4	75.0
4	1:03.771	102.19	23.7	44.1	75.6
5	1:02.650	100.39	24.2	44.9	75.1
7	1:02.514	100.18	22.8	44.9	74.2
6	1:02.404	100.00	23.7	45.2	74.7
out	0:12.565	20.14	1.4	7.0	21.9
in	0:09.377	15.03	0.1	40.0	75.1

The graph shows GPS Speed (mph) on the y-axis (ranging from 20.0 to 80.0) and Distance (mi) on the x-axis (ranging from 0.0 to 4.0). The graph displays two lines: a blue line representing the overall speed profile and a red line representing the lap-by-lap speed profile. The blue line shows a series of peaks and troughs, indicating the speed profile of the race. The red line shows the speed profile for each lap, with the lap times and percentages listed in the table above.



Select the desired file double clicking on it and start analysing sampled data. A lot of pages, graphs and images will be available.



## 11 – New firmware upgrade



Our technicians and engineers are constantly working to improve both the firmware (the application that manages your device) and the software (the application you install on your PC).

Each time a new firmware and/or software version is available the icon here above appears with an arrow indicating that something is available for download.

Click it and freely download the new applications.

The screenshot shows the RaceStudio3 (64 bit) 3.82.09 interface. On the left, a 'Connected Devices' panel shows 'MXq ID 1620415'. The main area displays a list of software updates. The 'MXm' row is highlighted with a red box. The table below shows the details of the updates:

Name	On the web	Downloaded	Info
<input checked="" type="checkbox"/> RaceStudio3 (64 bit)	3.82.13		
<input type="checkbox"/> MXS v2	02.42.74	02.42.74	
<input checked="" type="checkbox"/> MXT 1.3	02.44.20	02.44.04	
<input checked="" type="checkbox"/> MXT 1.3 Strada	02.44.20	02.44.02	
<input checked="" type="checkbox"/> MXm	02.44.20	02.44.04	
<input type="checkbox"/> MXm v2	02.42.74	02.42.74	
<input type="checkbox"/> MXsl	02.44.04	02.44.04	
<input type="checkbox"/> MyChron5	01.32.08	01.32.08	
<input type="checkbox"/> MyChron5-660	02.40.75	02.40.75	
<input type="checkbox"/> MyChron5-660 v2	02.42.62	02.42.62	
<input type="checkbox"/> MyChron5S	02.44.04	02.44.04	
<input type="checkbox"/> MyChron5S v2	02.42.62	02.42.62	
<input checked="" type="checkbox"/> MyChron6	02.46.03	02.44.12	
<input checked="" type="checkbox"/> PDM08	02.44.20	02.44.04	
<input checked="" type="checkbox"/> PDM32	02.44.20	02.44.04	
<input type="checkbox"/> SW4	02.44.04	02.44.04	
<input type="checkbox"/> SmartyCam 3 Corsa	01.17.01	01.17.01	
<input type="checkbox"/> SmartyCam 3 Dual	01.17.01	01.17.01	
<input type="checkbox"/> SmartyCam 3 GP	01.17.01	01.17.01	
<input type="checkbox"/> SmartyCam 3 Sport	01.17.01	01.17.01	
<input type="checkbox"/> SmartyCam HD	01.04.62	01.04.62	

Once the new firmware has been downloaded connect your device to the PC via Wi-Fi to perform a firmware upgrade. In a few seconds the device is ready.

## 12 – RPM

MXm and MXq can receive RPM value from the ECU. If on the contrary your vehicle does not have an ECU you can sample RPM using:

- the wire labelled “RPM” of MXm 37 pins connector harness you find in the kit
- the wire labelled “RPM in” of MXq 8 pins Binder 712 female connector harness labelled “CAN ECU”

### 12.1 – RPM from ECU

To get the RPM from the ECU you only need to connect your logger to the ECU and it will automatically sample that value.

### 12.2 – RPM via a 5-50V square wave or coil (150-400V)

If your vehicle has no ECU you need to connect the wire labelled RPM to the ignition system. This way the logger can read the signal from the low voltage of the coil (whose peak can be from 150 to 400 V) or from a possible square wave (the peak can be from 5 to 50 V). The image below shows an example of wiring of the ignition system.

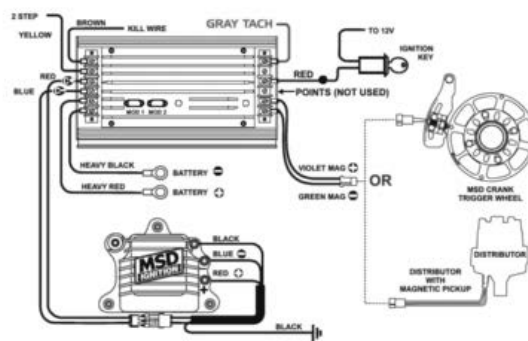

The output labelled “GRAY TACH” gives a 5-50V output that can be directly sampled by the logger.

In case the vehicle ignition system has no output you need to connect the logger to the low voltage of the coil as shown in the following images.

**Point 1:** low voltage of the coil

**Point 2:** connected to the spark plug

**Point 3:** connected to the +12V of the battery

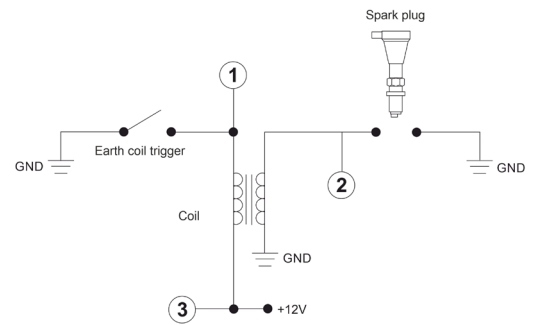
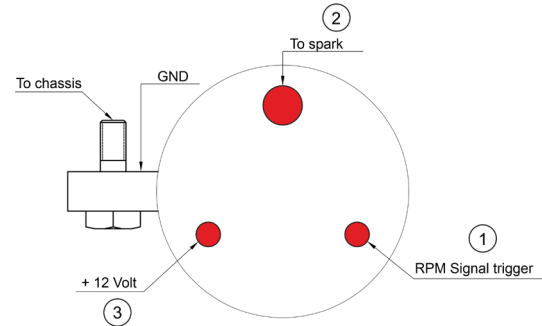



Once the logger connected to RPM signal you can set its parameters in channels tab of RaceStudio 3.

The screenshot shows the RaceStudio 3 interface with the Channels tab selected. A table lists various channels, and a 'Channel Settings' dialog box is open for the RPM channel. The dialog box has several fields: Name (RPM), Function (Engine RPM), Sensor (RPM Sensor), Sampling Frequency (20 Hz), RPM Max (16000), and RPM Factor (/1). Three dropdown menus are open on the right side of the interface, with red lines indicating their selection: the first dropdown shows '20 Hz' selected, the second shows '16000' selected, and the third shows '/1' selected. The background table shows the RPM channel with a checked box and the following parameters: max: 16000 ; factor: /1 ;

ID	Name	Function	Sensor	Unit	Freq	Parameters	
RPM	<input checked="" type="checkbox"/>	RPM	Engine RPM	RPM Sensor	rpm	20 Hz	max: 16000 ; factor: /1 ;
Ch	<input type="checkbox"/>	Ch	Voltage	Generic 0-5 V	mV	20 Hz	
Acc1	<input checked="" type="checkbox"/>	InlineAcc	Inline Acceleration	Internal Accelerometer	g 0.01	50 Hz	
Acc2	<input checked="" type="checkbox"/>	Lat					
Acc3	<input checked="" type="checkbox"/>	Ver					
Gyr1	<input checked="" type="checkbox"/>	Roll					
Gyr2	<input checked="" type="checkbox"/>	Pitch					
Gyr3	<input checked="" type="checkbox"/>	Yaw					
PAccu	<input checked="" type="checkbox"/>	GP					
Spd	<input checked="" type="checkbox"/>	GP					
Alt	<input checked="" type="checkbox"/>	Alti					
OdD	<input checked="" type="checkbox"/>	Odc					
Luma	<input checked="" type="checkbox"/>	Lun					
Fuel	<input type="checkbox"/>	Fue					
LogT	<input checked="" type="checkbox"/>	Log					
POTCA	<input type="checkbox"/>	POT					

## 13 – Connection with SmartyCam

MXm and MXq can be connected to AiM SmartyCam as shown in the images below.

For further information concerning SmartCam3 series refer to the related manuals you can download from “Documentation” area of AiM website [www.aim-sportline.com](http://www.aim-sportline.com).

To connect the loggers to SmartyCam connect their CAN cable to:

- cable labelled “EXP” of MXm 37 pins connection harness
- MXq cable of 5 pins Binder 712 female connector





## 14 – Technical specifications and drawings

---

• Display resolution	268x128 pixels
• Display pages	Up to 8 freely configurable
• Backlight	7 configurable RGB colour
• Ambient light sensor	Yes
• Shift lights	5 configurable RGB LEDs
• Alarm LEDs	2 configurable RGB LEDs
• CAN connections	2
• MXm Analog inputs	4 fully configurable, max 1.000 Hz each
• MXq Analog inputs	1 fully configurable max 500Hz
• MXm Digital inputs	2 speed inputs, coil RPM input
• MXq Digital inputs	Low level coil RPM input, 0-5V square wave
• <b>Digital outputs (MXm only)</b>	2 high side
• Integrated track database	Yes
• MXm Inertial platform	9 axis internal platform
• MXq inertial platform	6 axis internal platfor,
• Wi-Fi connection	Yes
• Integrated GPS	10Hz GPS+Glonass
• ECU Connection	CAN, RS232, K-Line
• External power	12V
• Internal Memory	4GB
• Pushbuttons	Metallic
• MXm Connectors	37 pins motorsport connector + 4 pins power connector
• MXq connectors	3 Binder 712 female connectors
• MXm body	Glass fiber reinforced Nylon
• MXq body	PA6 GS30%
• Weight	330g
• Dimensions	137x88.4x31.9mm
• Waterproof	IP65
• Analysis software	Race Studio Analysis freely downloadable from <a href="http://www.aim-sportline.com">www.aim-sportline.com</a>



MXm dimensions in mm [inches]

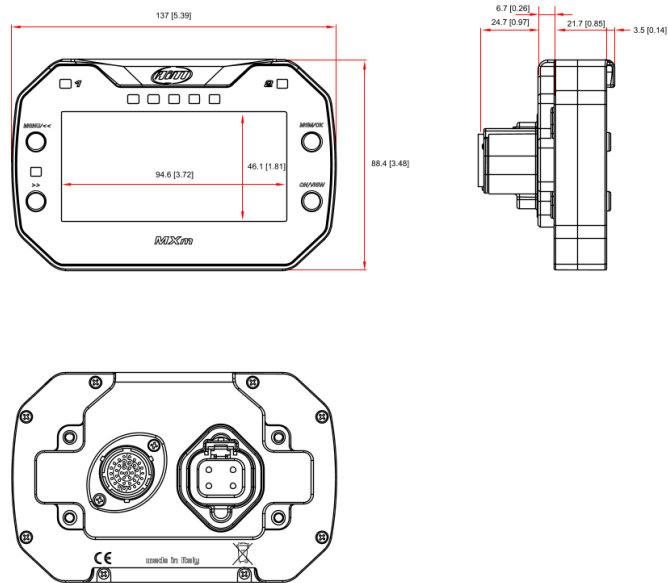

MXm pinout

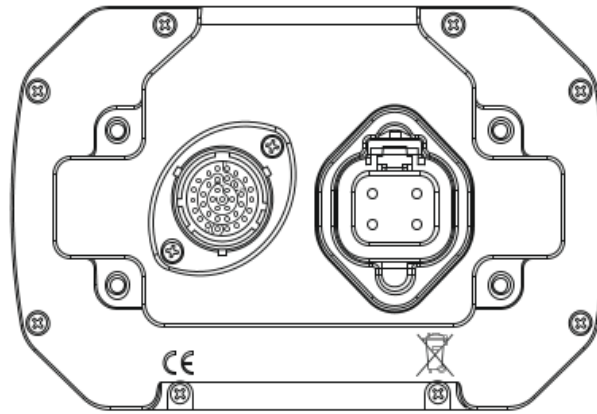

37 pins Motorsport  
male connector  
front view

4 pins power  
male connector  
front view

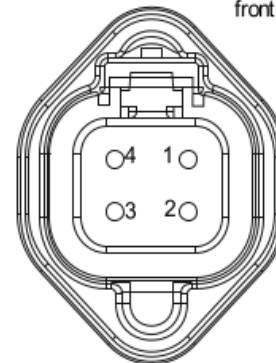
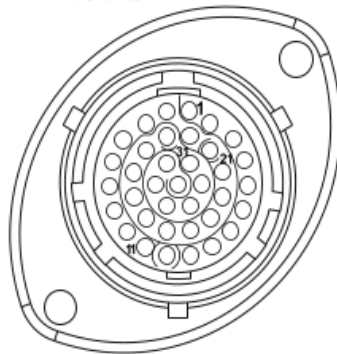

Pin	Pin function
1	9-15V Power input
2	Battery Ground
3	CAN+ Exp
4	Ground
5	+Vbattery CAN
6	CAN- exp
7	+Vbext
8	CAN1+ ECU/RS232TX
9	CAN1- ECU/RS232RX
10	Ground
11	ECU K-Line
12	USB D+
13	USB D-
14	Ground
15	RPM
16	Ground
17	+Vbattery
18	Speed2
19	Speed1

Pin	Pin function
20	Ground
21	+Vbattery
22	Analog Input 1
23	Analog GND
24	+Vbattery
25	+Vreference
26	Analog Input 2
27	Analog GND
28	+Vbattery
29	+Vreference
30	Analog Input 3
31	Analog GND
32	+Vbattery
33	+Vreference
34	Analog Input 4
35	Analog GND
36	+Vbattery
37	+Vreference

Pin	Pin function
1	High side output 2
2	9-15V power input
3	9-15V power input
4	High side output1

## MXm 37 pins Deutsch connector harness

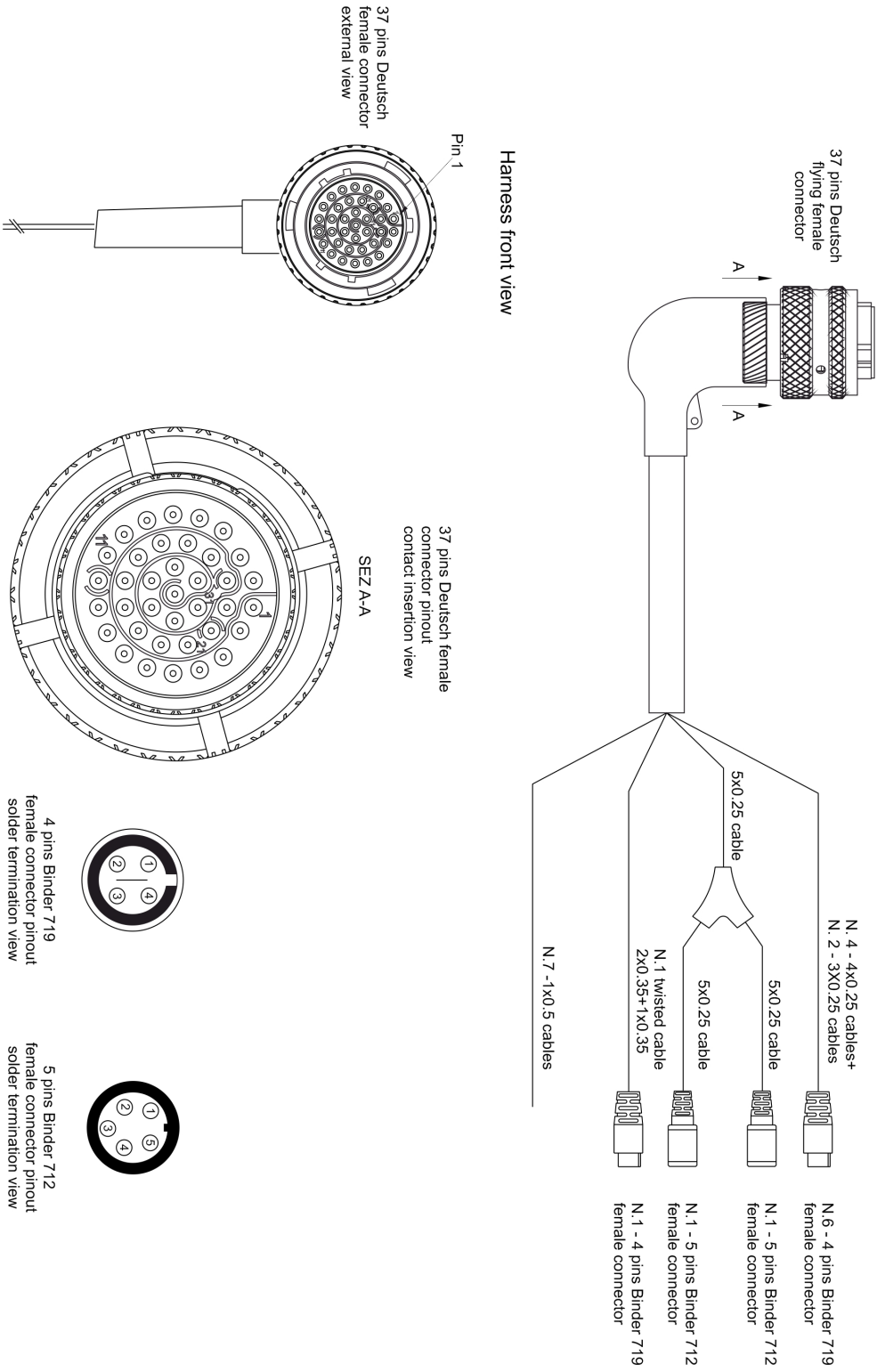

Cables ending with 4 pins Binder 719 female connector						
37 pins Deutsch connector pin	Cable colour	Destination connector pin	Cable Type	Length	Channel	Label
22 23 24 25	White Black Red Blue	1 2 3 4	4x0.25mm <sup>2</sup>	340 mm	+Analog input 1 GND Vbattery Vreference	Channel 1
26 27 28 29	White Black Red Blue	1 2 3 4	4x0.25mm <sup>2</sup>	340 mm	+Analog input 2 GND Vbattery Vreference	Channel 2
30 31 32 33	White Black Red Blue	1 2 3 4	4x0.25mm <sup>2</sup>	360 mm	+Analog input 3 GND Vbattery Vreference	Channel 3
34 35 36 37	White Black Red Blue	1 2 3 4	4x0.25mm <sup>2</sup>	360 mm	+Analog input 4 GND Vbattery Vreference	Channel 4
19 20 21	White Black Blue n.c.	1 2 3 4	3x0.25mm <sup>2</sup>	320 mm	Speed 1 GND Vbattery n.c.	Speed 1
18 16 17	White Black Blue n.c.	1 2 3 4	3x0.25mm <sup>2</sup>	320 mm	Speed 2 GND Vbattery n.c.	Speed 2
12 14 13	White twisted Black Blue twisted n.c.	1 2 3 4	Twisted 2x0.35+1x0.35	1100 mm	USB D+ GND USB D- n.c.	USB

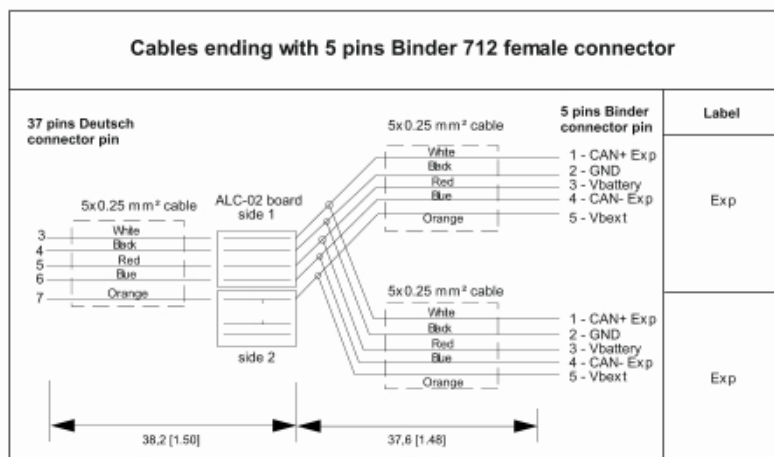

Flying leads				
37 pins Deutsch connector pin	Cable colour	Cable type	Length	Label
15	White	1x0.5 mm <sup>2</sup>	550 mm	RPM
2 1	Black Red	1x0.5 mm <sup>2</sup> 1x0.5 mm <sup>2</sup>	550 mm	GND 9-15V Power input
8 9 10 11	White Blue Black Blue	1x0.5 mm <sup>2</sup> 1x0.5 mm <sup>2</sup> 1x0.5 mm <sup>2</sup> 1x0.5 mm <sup>2</sup>	550 mm	CAN 1+ ECU RS232TX CAN 1- ECU RS232RX Kline GND kLINE

## MXq Dimensions in mm [inches]

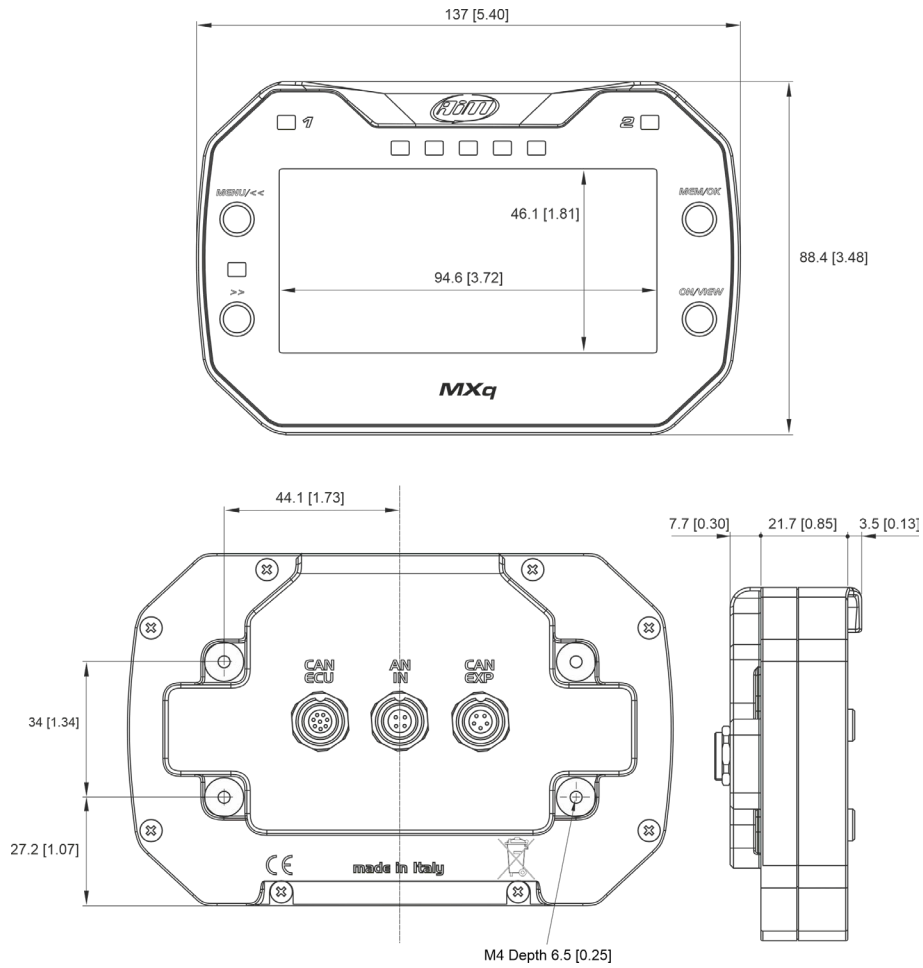

**MXq pinout**

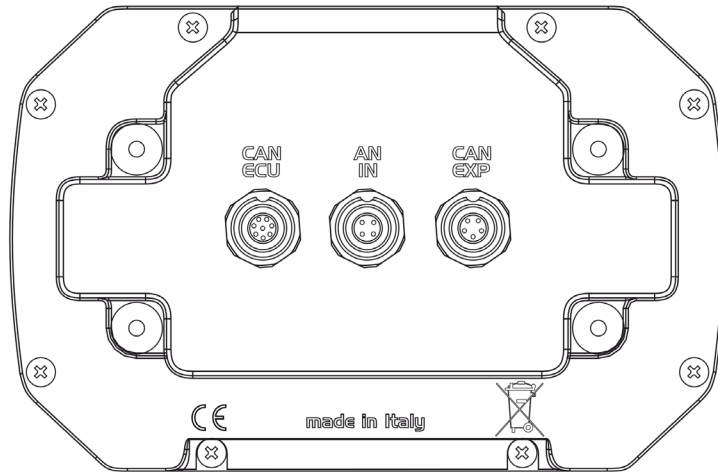

**CAN  
ECU**



8 pins Binder 712 female  
connector pinout  
front view

ECU connector	
1	CAN ECU+
2	CAN ECU-
3	+Vbext
4	RS232TX
5	RS232RX
6	K-Line
7	GND
8	RPM in

**AN  
IN**

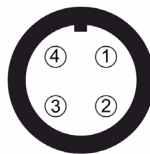

4 pins Binder 712 female  
connector pinout  
front view

Analog Input connector	
1	Analog input 1
2	Analog GND
3	+Vb out
4	+VReference

**CAN  
EXP**

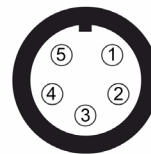

5 pins Binder 712 female  
connector pinout  
front view

EXP Connector	
1	CAN+
2	GND
3	+Vb out
4	CAN-
5	+Vbext