

**AUDI ECU for**  
**A3, A4, TT (1800 cc)**  
**A6 (1800-2000 cc)**



## INTRODUCTION

AIM has developed special applications for many of the most common ECUs: by special applications we mean user-friendly systems which allow to easily connect your ECU to our high tech data loggers: user needs only to install harness between the **logger** and the ECU.

Once connected, the logger displays (and/or records, depending on the logger and on the ECU data stream) values like RPM, engine load, throttle position (TPS), air and water temperatures, battery voltage, speed, gear, lambda value (air/fuel ratio) analog channels...

All AIM loggers include – free of charge – **Race Studio 2** software, a powerful tool to configure the system and analyze recorded data on your PC.

**Warning: once the ECU is connected to the logger, it is necessary to set it in the logger configuration in Race Studio 2 software.**

**Select Manufacturer “Bosch” Model “AUDI”.**

**Refer to Race Studio Configuration user manual for further information concerning the loggers configuration.**



## INDEX

Chapter 1 – Car Models .....	3
Chapter 2 – CAN communication Setup .....	4
Chapter 3 – Connection with AIM loggers .....	5
Chapter 4 – Bosch ME 7.5 communication protocol .....	6

## Chapter 1 – Car Models

Bosch ME 7.5 ECU is installed as stock one on the following car models:

- Audi A3 1800 20V Turbo 180 CV
- Audi A4 1800 20V 125 CV
- Audi A4 1800 20V 127 CV
- Audi A4 1800 20V Turbo 150 CV
- Audi A4 1800 20V Turbo 163 CV
- Audi A4 1800 20V Turbo 190 CV
- Audi A4 2000 20V 130CV
- Audi A6 1800 20V 125CV
- Audi A6 1800 20V Turbo 150 CV
- Audi A6 1800 20V Turbo 180 CV
- Audi A6 2000 20V 130 CV
- Audi TT 1800 20V Turbo 150 CV
- Audi TT 1800 20V Turbo 180 CV
- Audi TT 1800 20V Turbo 225 CV

## Chapter 2 – CAN communication Setup

Bosch ME 7.5 ECU is equipped with a CAN communication protocol used to communicate parameters to a data logger and has “X11” connector used to communicate with an external logger.

The images here below show the standard CAN communication setup on top and the ECU wiring diagram on bottom. In this second image is highlighted “CAN” connection.

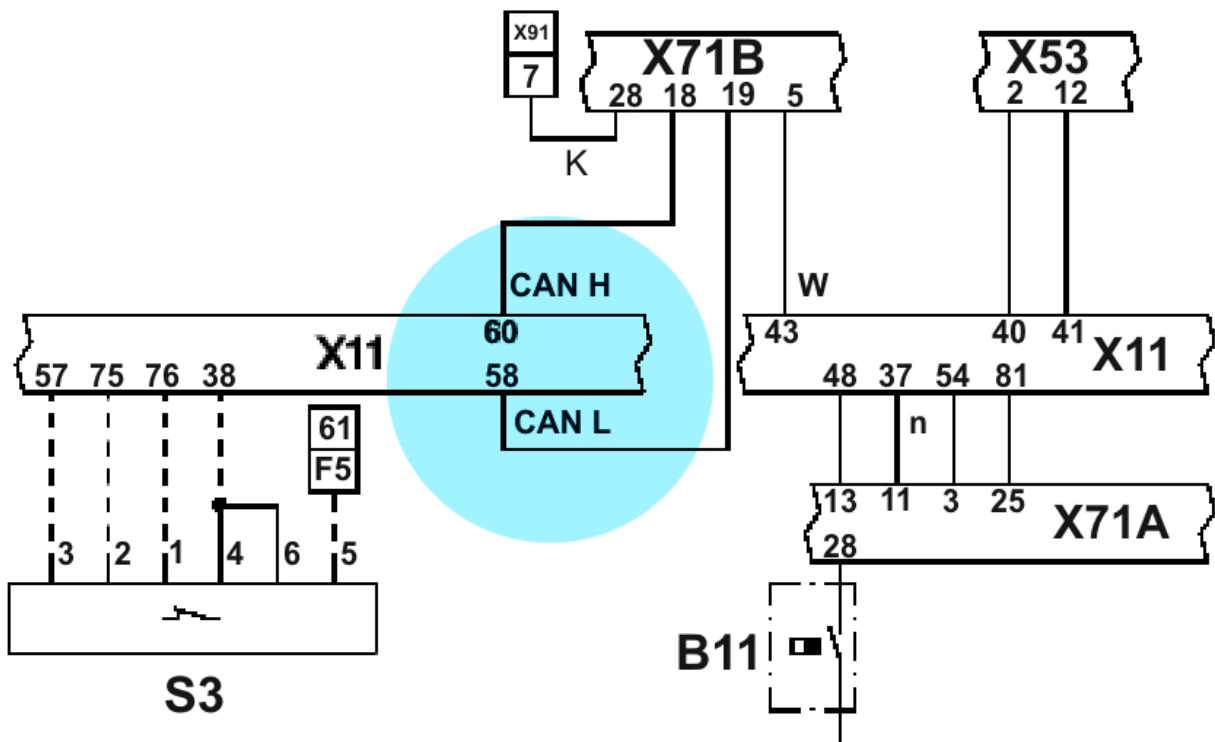
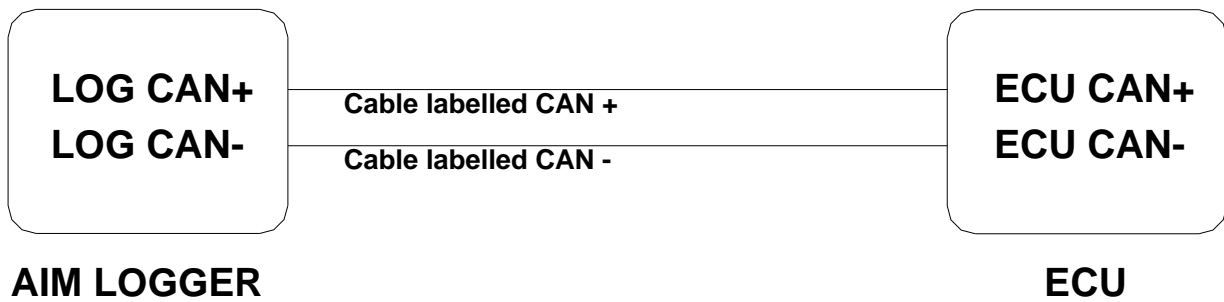

## Chapter 3 – Connection with AIM loggers

To connect Bosch ME 7.5 ECU to AIM loggers use the “X11” male connector shown here below and:

- connect pin 60 of X11 connector to AIM cable labelled CAN+
- connect pin 58 of X11 connector to AIM cable labelled CAN-

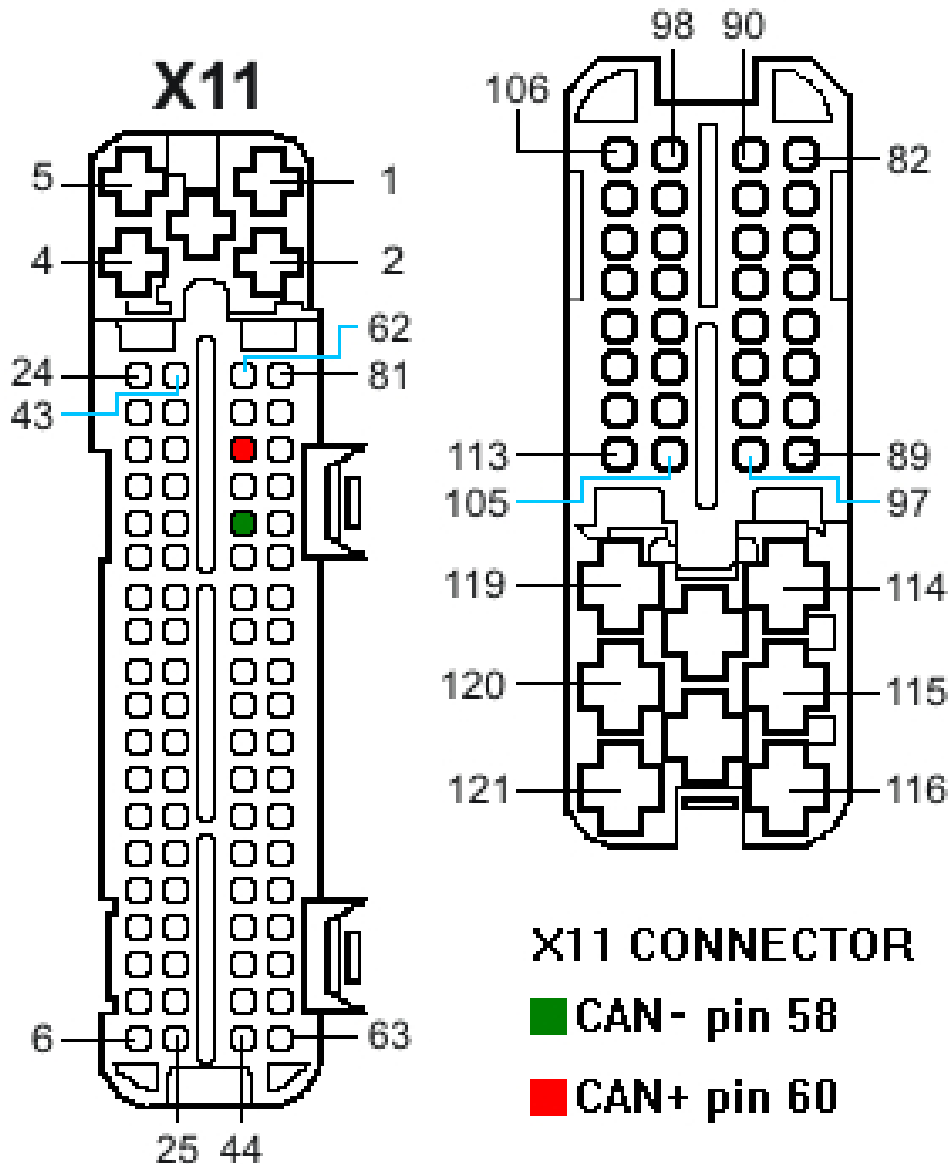

## Chapter 4 – Bosch ME 7.5 communication protocol

Channels received by AIM loggers connected to Bosch ME 7.5 ECU are:

<b>ID</b>	<b>CHANNEL NAME</b>	<b>FUNCTION</b>
ECU_1	AUDI_RPM	RPM
ECU_2	AUDI_SPEED1	Speed
ECU_3	AUDI_WATERTEMP	Water temperature
ECU_4	AUDI_ENGINEMOMENT	Engine Torque
ECU_5	AUDI_AIRTEMP	Manifold Air Temperature
ECU_6	AUDI_GASPERC	Pedal position sensor
ECU_7	AUDI_BRAKEPRESS	Brake pressure sensor
ECU_8	AUDI_SPEED2	Speed 2
ECU_9	AUDI_SPEEDDASH	Speed
ECU_10	AUDI_ACCLAT	Lateral acceleration
ECU_11	AUDI_STEERMOMENT	Steering Torque
ECU_12	AUDI_ATMTEMP	Atmospheric Temperature
ECU_13	AUDI_OILTEMP	Oil Temperature
ECU_14	AUDI_FRLF_SPEED	Front Left Speed sensor
ECU_15	AUDI_FRRG_SPEED	Front Right Speed sensor
ECU_16	AUDI_RRLF_SPEED	Rear Left Speed sensor
ECU_17	AUDI_RRRG_SPEED	Rear Right Speed Sensor
ECU_18	AUDI_YAWRATE	Gyroscope
ECU_19	AUDI_STEERSPEED	Steering speed
ECU_20	AUDI_STEERANGLE	Steering angle
ECU_21	AUDI_BRAKE	Brake sensor
ECU_22	AUDI_FUEL	Fuel sensor
ECU_23	AUDI_GEAR	Engaged gear
ECU_24	AUDI_ENGOILT	Engine oil temperature
ECU_25	AUDI_TPS	Throttle position sensor
ECU_26	AUDI_CLUTCH	Switch Clutch
ECU_27	AUDI_BOOST_PRESS	Boost pressure
ECU_28	AUDI_ENGINE_MOMENT	Engine torque
ECU_29	AUDI_SHIFTING_ACTIVE	Shifting in progress
ECU_30	AUDI_TIP_TRONIK_DW	Tiptronic down
ECU_31	AUDI_TIP_TRONIK_UP	Tiptronic down
ECU_32	AUDI_SIN_NAM	
ECU_33	AUDI_SIN_NEW1	
ECU_34	AUDI_SIN_NEW2	
ECU_35	AUDI_SIN_NAB	
ECU_36	AUDI_SIP_PK1	
ECU_37	AUDI_SIP_PK2	